

Light efficiency:



Output: 661 lm

Light quality:



Peak: 1357 cd

Power: 15.1 W

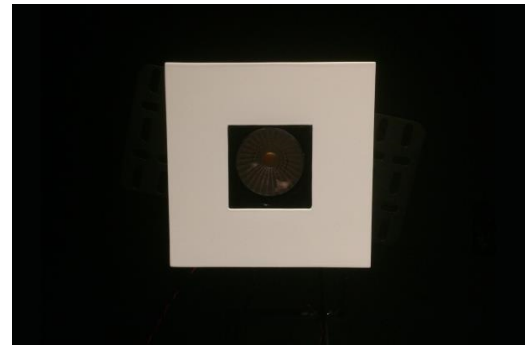

Beam angle

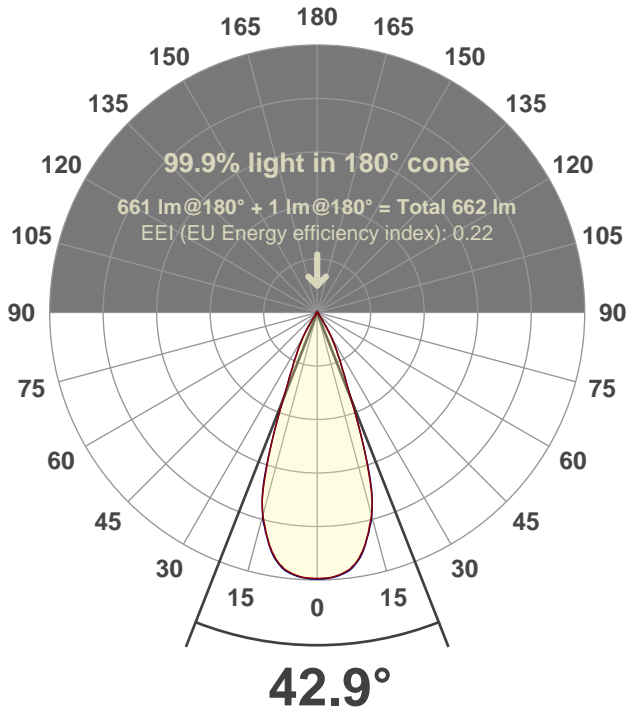

Test number:

CR4D-S-FL-C14-30k-55 (GRF-CZ20-WF-SQ)

Luminaire Model:

Core 4" Square Flat C14 30K 55°

Date and time:

3/31/2017 2:29:38 PM

LUM: 661

Spectra

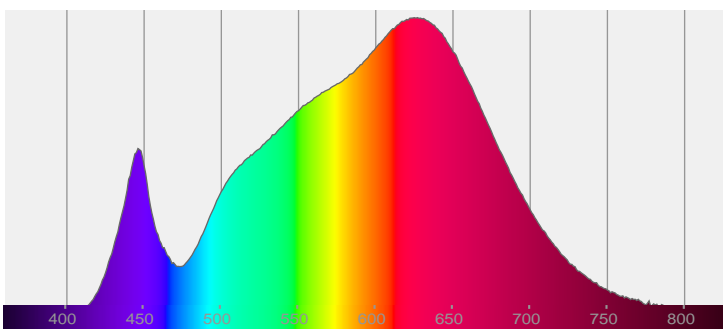

CRI: 92.4 (R1-R8)

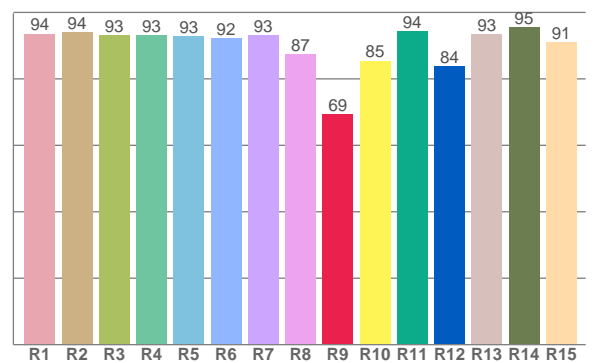

Color parameters

Color rendering index	Red component	Color fidelity	Color gamut	Color quality scale	Color coordinate cie 1931	Color coordinate cie 1931	Color coordinate	Color coordinate	Color deviation from black body
CRI	CRI R9	TM30 R <sub>f</sub>	TM30 R <sub>g</sub>	CQS	x	y	u	v	Δuv
92.4	69.2	90.3	103.1	90.2	0.428	0.399	0.247	0.345	-0.0007

**$R_f$  90.3**  
Fidelity index  $R_f$

**$R_g$  103.1**  
Gammut index  $R_g$

TM30: 90.3

TM-30Color

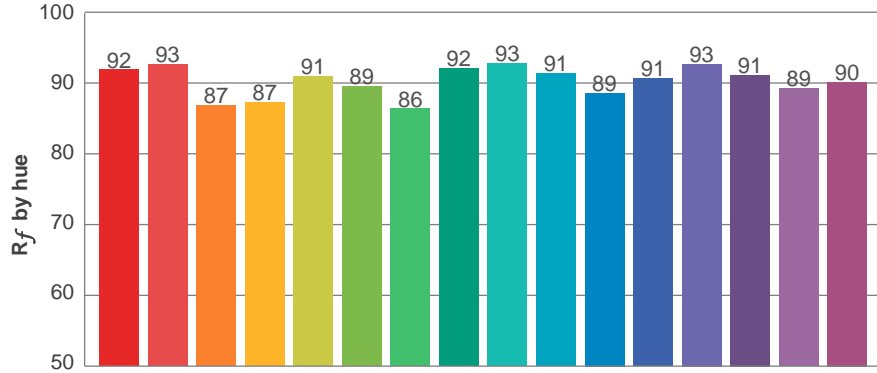

Hue Bin	$R_f$	Graphic shifts (%)	
		Chroma	Hue
1	92	-3%	-3%
2	93	-3%	3%
3	87	0%	7%
4	87	4%	7%
5	91	6%	5%
6	89	7%	-1%
7	86	5%	-7%
8	92	1%	-5%
9	93	-2%	-4%
10	91	-4%	0%
11	89	-2%	7%
12	91	3%	4%
13	93	5%	0%
14	91	6%	-4%
15	89	3%	-6%
16	90	0%	-8%

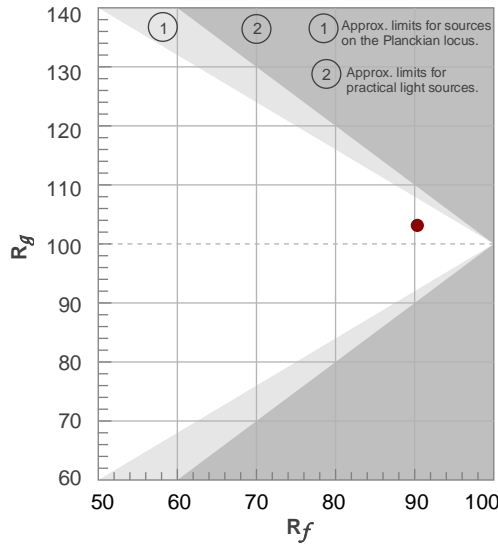

Color vector graphics

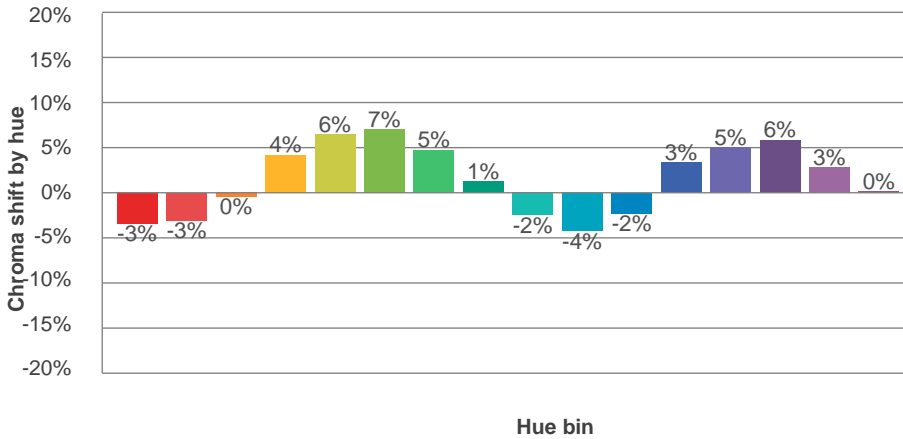
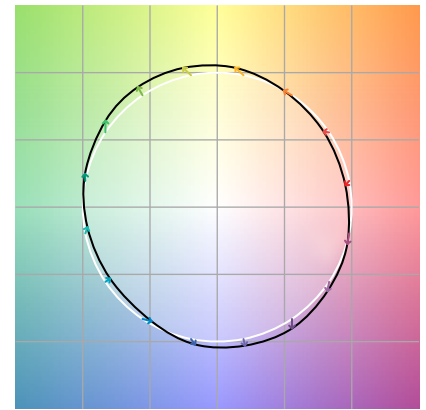

Color distortion

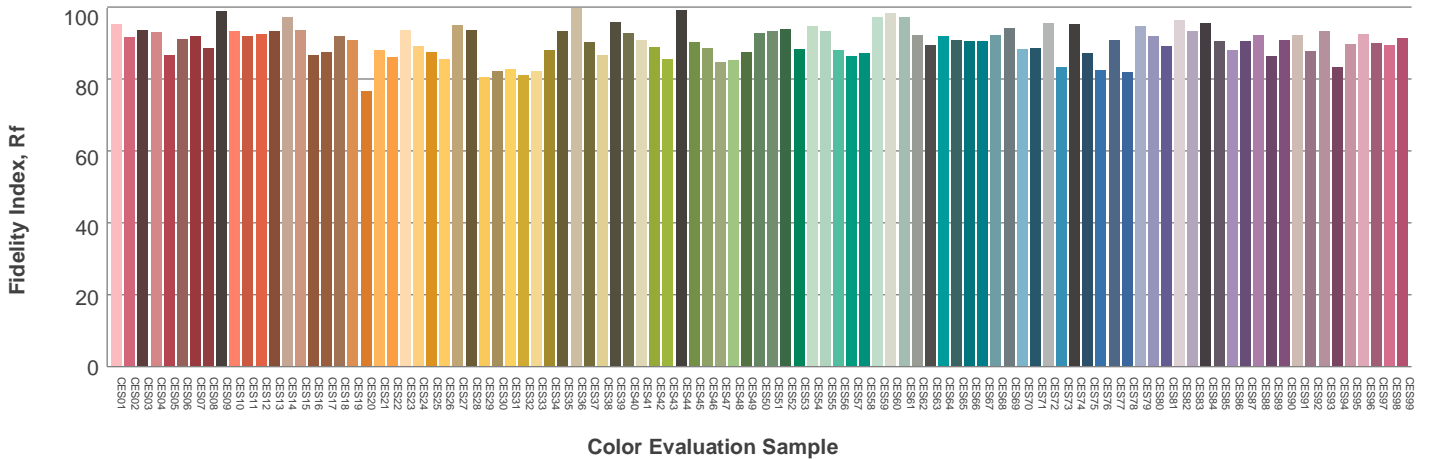

Beam details

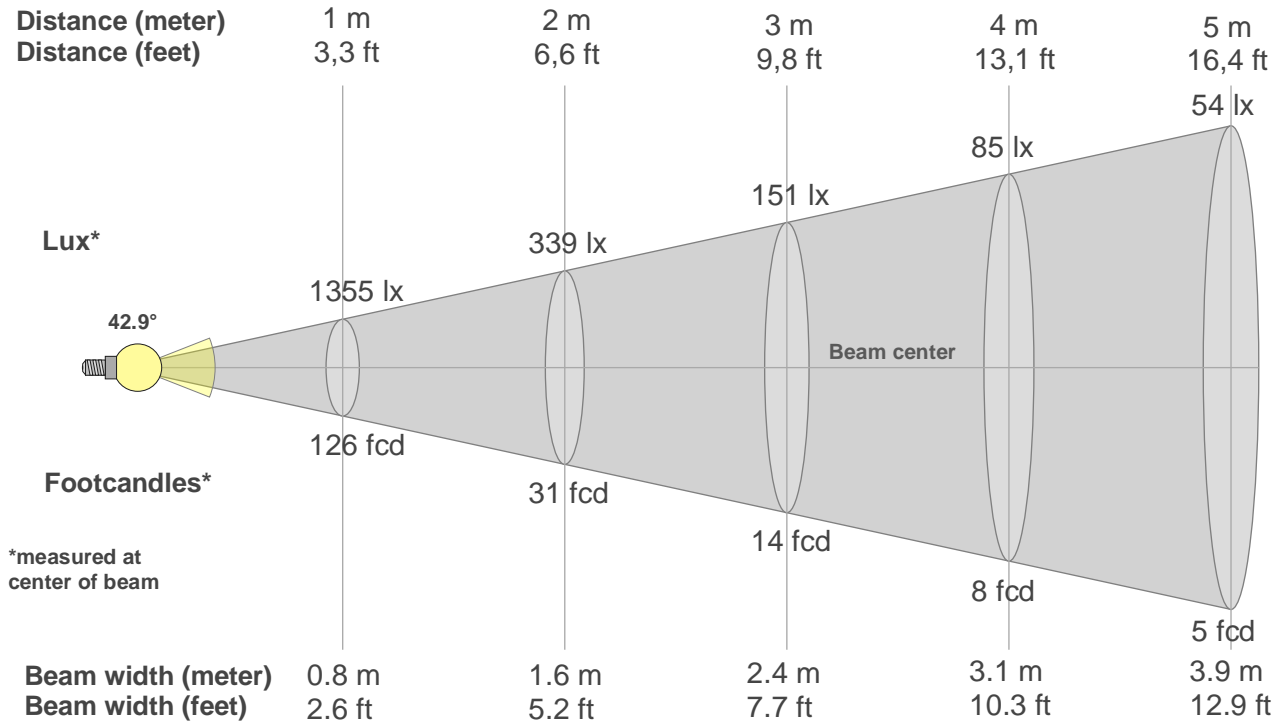

Beam intensities from 1-20m

1m	2m	3m	4m	5m	6m	7m	8m	9m	10m	11m	12m	13m	14m	15m	16m	17m	18m	19m	20m
3.3ft	6.6ft	9.8ft	13.1ft	16.4ft	19.7ft	23ft	26.2ft	29.5ft	32.8ft	36.1ft	39.4ft	42.7ft	45.9ft	49.2ft	52.5ft	55.8ft	59.1ft	62.3ft	65.6ft
1355lx	339lx	151lx	85lx	54lx	38lx	28lx	21lx	17lx	14lx	11lx	9lx	8lx	7lx	6lx	5lx	5lx	4lx	4lx	3lx
125.9fcd	31.5fcd	14fcd	7.9fcd	5fcd	3.5fcd	2.6fcd	2fcd	1.6fcd	1.3fcd	1fcd	0.9fcd	0.7fcd	0.6fcd	0.6fcd	0.5fcd	0.4fcd	0.4fcd	0.3fcd	0.3fcd

Intensities in 0° c-plane

0°	2°	4°	6°	8°	10°	12°	14°	16°	18°	20°	22°	24°	26°	28°	30°	32°	34°	36°	38°
1355	1350	1343	1328	1302	1257	1192	1109	1015	843	628	432	322	251	197	147	101	67	38	20
100%	100%	99%	98%	96%	93%	88%	82%	75%	62%	46%	32%	24%	19%	15%	11%	7%	5%	3%	1%

Intensities in 90° c-plane

0°	2°	4°	6°	8°	10°	12°	14°	16°	18°	20°	22°	24°	26°	28°	30°	32°	34°	36°	38°
1355	1353	1347	1333	1308	1264	1196	1117	1015	857	628	429	324	252	197	149	103	66	38	19
100%	100%	99%	98%	97%	93%	88%	82%	75%	63%	46%	32%	24%	19%	15%	11%	8%	5%	3%	1%

Intensities in 180° c-plane

0°	2°	4°	6°	8°	10°	12°	14°	16°	18°	20°	22°	24°	26°	28°	30°	32°	34°	36°	38°
1355	1350	1343	1328	1302	1257	1192	1109	1015	843	628	432	322	251	197	147	101	67	38	20
100%	100%	99%	98%	96%	93%	88%	82%	75%	62%	46%	32%	24%	19%	15%	11%	7%	5%	3%	1%

Intensities in 270° c-plane

0°	2°	4°	6°	8°	10°	12°	14°	16°	18°	20°	22°	24°	26°	28°	30°	32°	34°	36°	38°
1355	1353	1347	1333	1308	1264	1196	1117	1015	857	628	429	324	252	197	149	103	66	38	19
100%	100%	99%	98%	97%	93%	88%	82%	75%	63%	46%	32%	24%	19%	15%	11%	8%	5%	3%	1%

Beam angle 50%	Field angle 10%	Cutoff angle 2,5%	Intensity ratio in 120° cone	Intensity ratio in 90° cone
42.9°	61.5°	74°	98.6%	98.0%

Light planning

Luminaire budgetary diagram

LAMPS (number of lamps)  
50

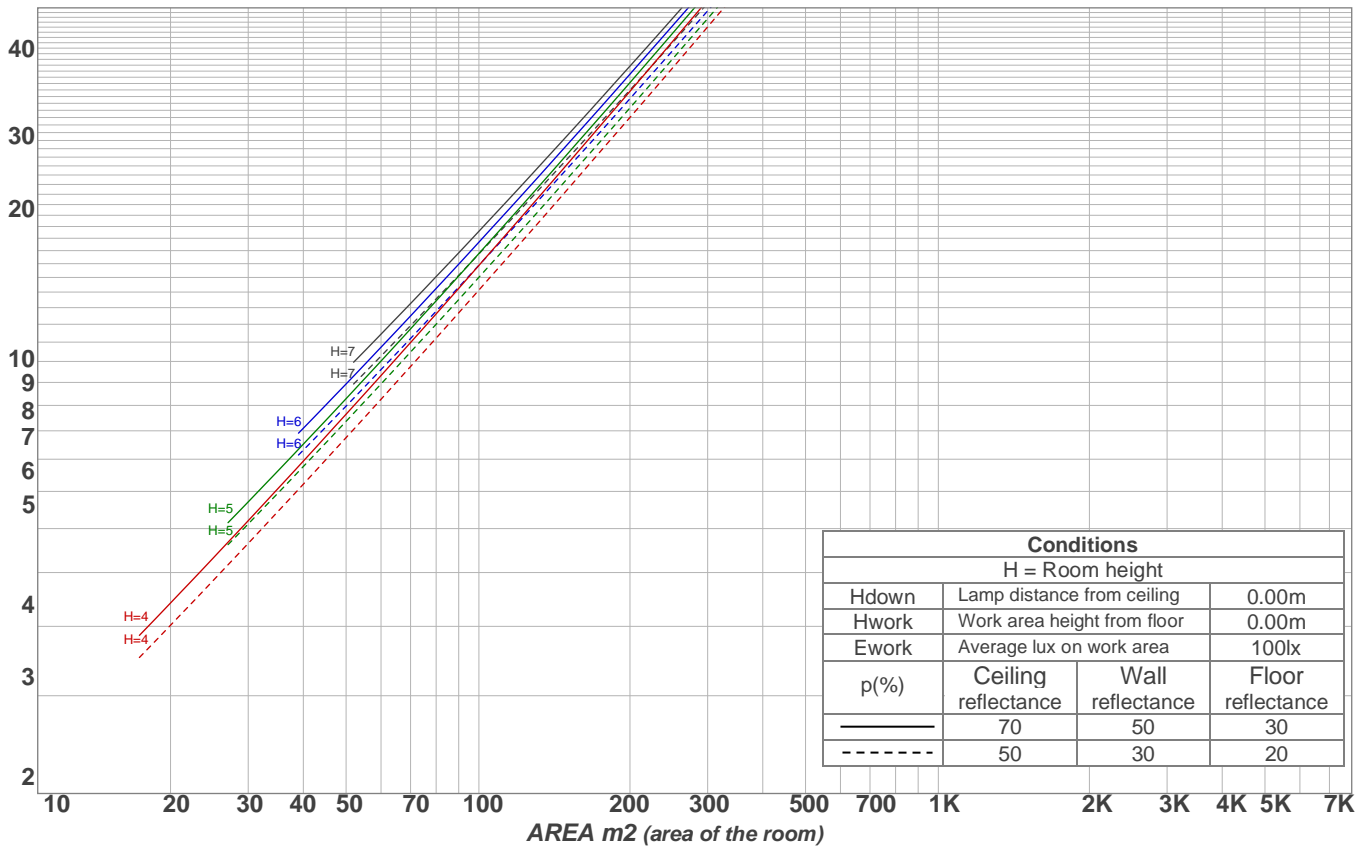

**Luminaire budgetary diagram**  
AREA m2 (area of the room)  
**Coefficients of Utilization**

Ceiling reflectance	80				70				50			30			10			0			
Wall reflectance	70	50	30	10	70	50	30	10	50	30	10	50	30	10	50	30	10	50	30	10	0
Floor reflectance	20	20	20	20	20	20	20	20	20	20	20	20	20	20	20	20	20	20	20	20	0
<b>RCR</b>	<b>(RCR: Room Cavity Ratio)</b>																				
	Room Values are expressed as percentage of Lumens delivered to the task surface																				
0	119	119	119	119	116	116	116	116	111	111	111	106	106	106	102	102	102	100	100	100	100
1	114	112	110	108	112	110	108	106	106	104	103	102	101	100	99	98	97	95	95	95	95
2	110	105	102	99	108	104	101	98	101	98	96	98	96	94	95	93	92	90	90	90	90
3	105	100	96	92	103	99	95	92	96	93	90	94	91	89	92	89	87	86	86	86	86
4	101	95	90	87	100	94	90	86	92	88	85	90	87	84	88	86	83	82	82	82	82
5	97	91	86	82	96	90	85	82	88	84	81	86	83	80	85	82	80	78	78	78	78
6	94	87	82	78	93	86	81	78	84	80	77	83	80	77	82	79	76	75	75	75	75
7	90	83	78	74	89	82	78	74	81	77	74	80	76	73	79	76	73	72	72	72	72
8	87	79	74	71	86	79	74	71	78	74	71	77	73	70	76	73	70	69	69	69	69
9	84	76	71	68	83	76	71	68	75	71	68	74	70	68	73	70	67	66	66	66	66
10	81	73	69	65	80	73	68	65	72	68	65	71	68	65	71	67	65	64	64	64	64

**Zonal Lumen Summary**

0°-10°	10°-20°	20°-30°	30°-40°	40°-50°	50°-60°	60°-70°	70°-80°	80°-90°
126 lm	296 lm	183 lm	39.4 lm	4.53 lm	2.85 lm	3.77 lm	2.85 lm	2.07 lm
90°-100°	100°-110°	110°-120°	120°-130°	130°-140°	140°-150°	150°-160°	160°-170°	170°-180°
0.000 lm	0.000 lm	0.000 lm	0.000 lm	0.000 lm	0.000 lm	0.000 lm	0.000 lm	0.000 lm

UGR

p Ceiling		70	70	50	50	30	70	70	50	50	30
p Walls		50	30	50	30	30	50	30	50	30	30
p Floor		20	20	20	20	20	20	20	20	20	20
Room size X Y		Viewing direction at right angles to lamp axis					Viewing direction parallel to lamp axis				
2H	2H	21.8	22.3	21.9	22.5	22.7	22.0	22.5	22.1	22.7	22.9
	3H	22.0	22.7	22.4	22.9	23.1	22.5	23.2	22.9	23.4	23.5
	4H	22.3	23.0	22.7	23.2	23.4	22.9	23.6	23.3	23.8	24.0
	6H	22.9	23.4	23.2	23.7	24.0	23.6	24.1	23.9	24.4	24.7
	8H	23.2	23.7	23.5	24.0	24.4	23.9	24.4	24.2	24.8	25.1
	12H	23.7	24.2	24.1	24.6	25.0	24.5	24.9	24.8	25.3	25.7
4H	2H	21.7	22.3	22.1	22.5	22.8	21.9	22.5	22.3	22.7	23.0
	3H	22.4	22.9	22.7	23.2	23.6	22.8	23.3	23.2	23.7	24.1
	4H	22.8	23.2	23.2	23.7	24.2	23.4	23.8	23.8	24.3	24.8
	6H	23.5	24.0	24.0	24.4	24.7	24.2	24.7	24.7	25.1	25.4
	8H	24.0	24.5	24.6	24.8	25.2	24.7	25.2	25.3	25.5	25.9
	12H	24.8	25.1	25.3	25.5	26.0	25.5	25.8	26.0	26.2	26.7
8H	4H	23.1	23.6	23.6	23.9	24.3	23.6	24.1	24.1	24.4	24.8
	6H	24.1	24.4	24.6	24.9	25.4	24.8	25.1	25.3	25.5	26.0
	8H	24.9	25.1	25.4	25.7	26.3	25.5	25.7	26.0	26.3	26.9
	12H	25.9	26.1	26.5	26.6	27.2	26.5	26.7	27.1	27.2	27.8
12H	4H	23.1	23.5	23.6	23.9	24.4	23.7	24.0	24.2	24.4	24.9
	6H	24.4	24.6	24.9	25.1	25.8	25.0	25.2	25.5	25.7	26.3
	8H	25.2	25.4	25.8	25.9	26.5	25.8	26.0	26.3	26.5	27.1
Corrected glare indices referring to 661 lm total luminous flux											