

Light efficiency:



Output: 764 lm

Light quality:



Peak: 1058 cd

Power: 15.1 W

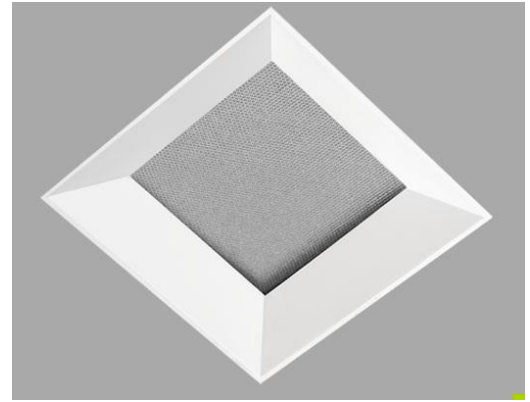

Beam angle

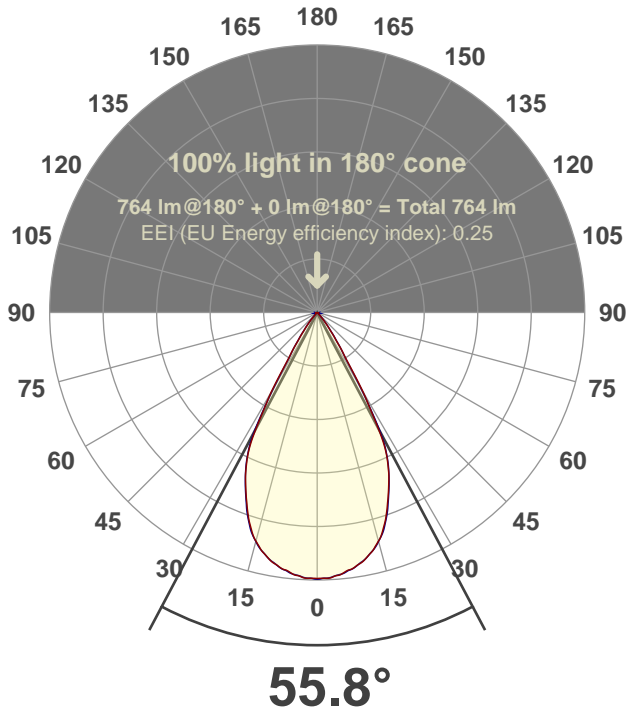

Test number:

CR4D-S-OR-A14-30k-55 (GRO-AD-WF-SQ)

Luminaire Model:

Core 4" Square Open Regress A14 30 to 19k 55°

Date and time:

5/3/2017 3:13:51 PM

LUM: 764

Spectra

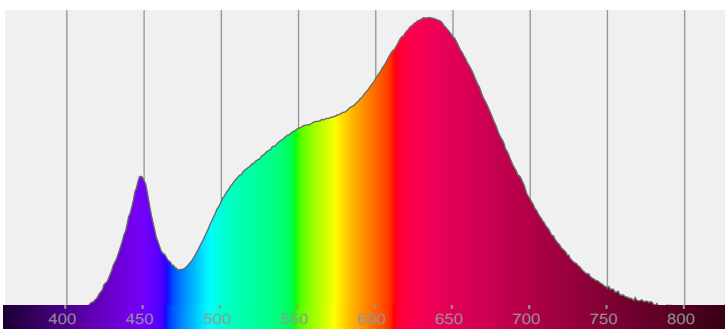

CRI: 96.0 (R1-R8)

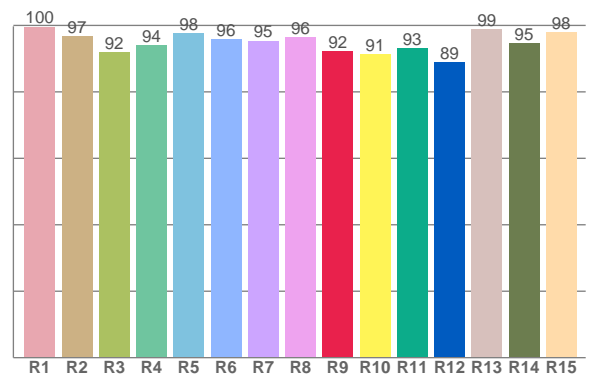

Color parameters

Color rendering index	Red component	Color fidelity	Color gamut	Color quality scale	Color coordinate cie 1931	Color coordinate cie 1931	Color coordinate	Color coordinate	Color deviation from black body
CRI	CRI R9	TM30 R _f	TM30 R _g	CQS	x	y	u	v	Δuv
96.0	92.1	93.4	104.2	93.3	0.435	0.403	0.250	0.347	-0.0002

R_f 93.4
Fidelity index R_f

R_g 104.2
Gammut index R_g

TM30: 93.4

TM-30Color

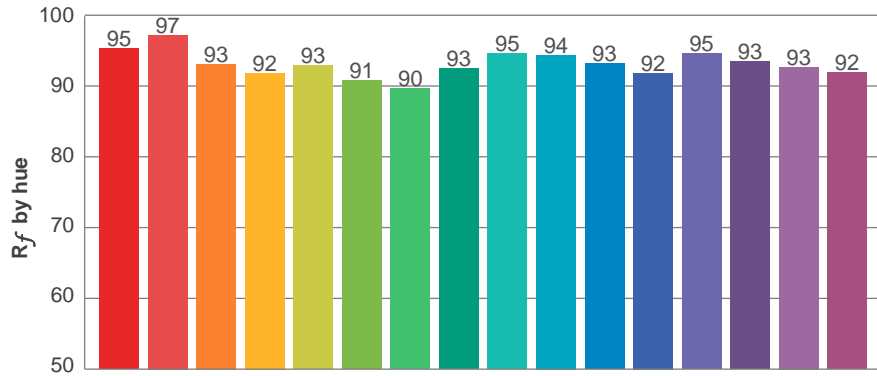

Hue Bin	R_f	Graphic shifts (%)	
		Chroma	Hue
1	95	-1%	-2%
2	97	-1%	1%
3	93	0%	4%
4	92	3%	4%
5	93	4%	4%
6	91	6%	1%
7	90	5%	-5%
8	93	3%	-4%
9	95	0%	-4%
10	94	-2%	-1%
11	93	-2%	4%
12	92	3%	3%
13	95	4%	0%
14	93	5%	-1%
15	93	3%	-3%
16	92	3%	-6%

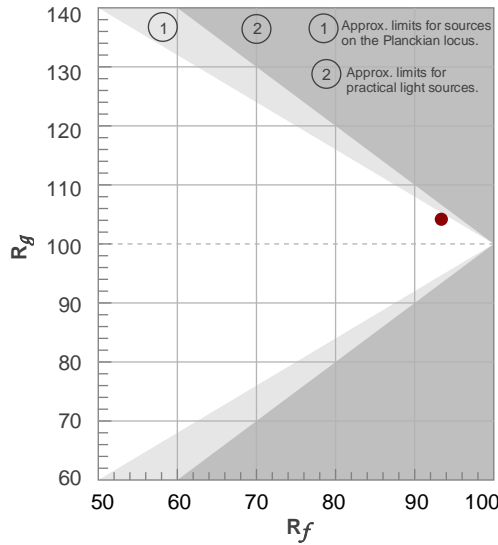

Color vector graphics

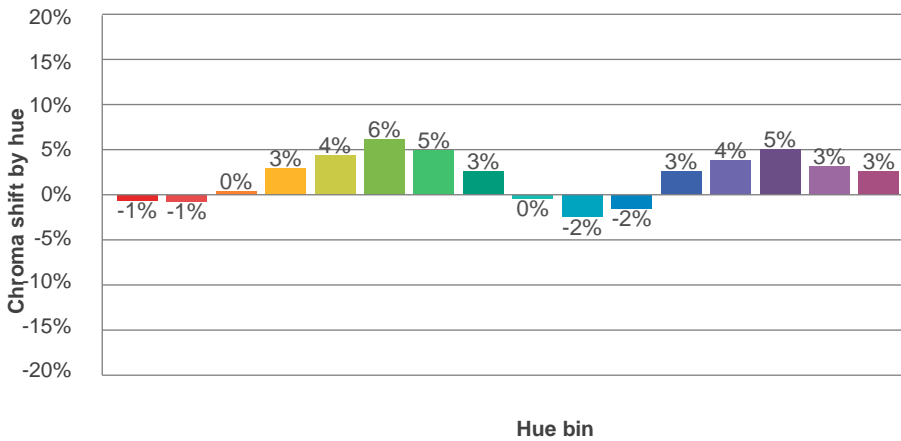
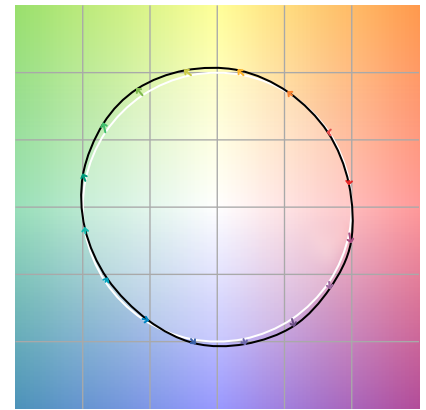

Color distortion

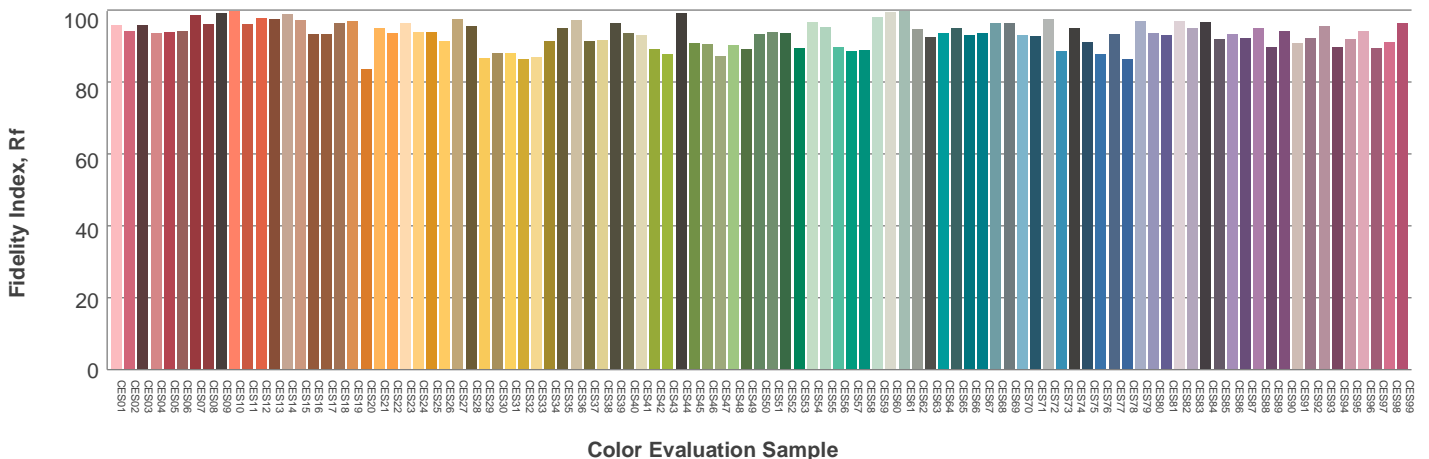

Beam details

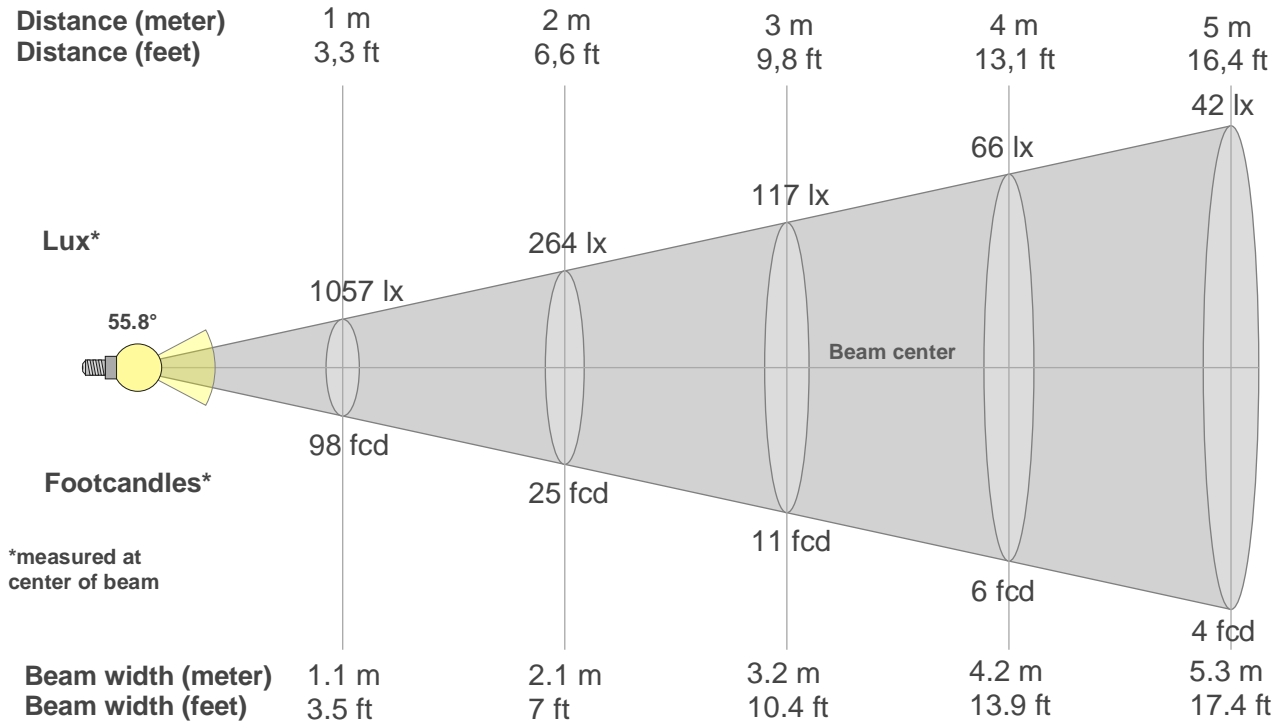

Beam intensities from 1-20m

1m	2m	3m	4m	5m	6m	7m	8m	9m	10m	11m	12m	13m	14m	15m	16m	17m	18m	19m	20m
3.3ft	6.6ft	9.8ft	13.1ft	16.4ft	19.7ft	23ft	26.2ft	29.5ft	32.8ft	36.1ft	39.4ft	42.7ft	45.9ft	49.2ft	52.5ft	55.8ft	59.1ft	62.3ft	65.6ft
1057lx	264lx	117lx	66lx	42lx	29lx	22lx	17lx	13lx	11lx	9lx	7lx	6lx	5lx	5lx	4lx	4lx	3lx	3lx	3lx
98.2fcd	24.5fcd	10.9fcd	6.1fcd	3.9fcd	2.7fcd	2fcd	1.5fcd	1.2fcd	1fcd	0.8fcd	0.7fcd	0.6fcd	0.5fcd	0.4fcd	0.4fcd	0.3fcd	0.3fcd	0.3fcd	0.2fcd

Intensities in 0° c-plane

0°	2°	4°	6°	8°	10°	12°	14°	16°	18°	20°	22°	24°	26°	28°	30°	32°	34°	36°	38°
1057	1055	1047	1036	1025	1008	985	956	922	873	816	758	700	630	511	373	225	156	106	73
100%	100%	99%	98%	97%	95%	93%	90%	87%	83%	77%	72%	66%	60%	48%	35%	21%	15%	10%	7%

Intensities in 90° c-plane

0°	2°	4°	6°	8°	10°	12°	14°	16°	18°	20°	22°	24°	26°	28°	30°	32°	34°	36°	38°
1057	1054	1047	1039	1026	1006	985	958	923	877	822	761	701	633	528	351	212	155	109	75
100%	100%	99%	98%	97%	95%	93%	91%	87%	83%	78%	72%	66%	60%	50%	33%	20%	15%	10%	7%

Intensities in 180° c-plane

0°	2°	4°	6°	8°	10°	12°	14°	16°	18°	20°	22°	24°	26°	28°	30°	32°	34°	36°	38°
1057	1055	1047	1036	1025	1008	985	956	922	873	816	758	700	630	511	373	225	156	106	73
100%	100%	99%	98%	97%	95%	93%	90%	87%	83%	77%	72%	66%	60%	48%	35%	21%	15%	10%	7%

Intensities in 270° c-plane

0°	2°	4°	6°	8°	10°	12°	14°	16°	18°	20°	22°	24°	26°	28°	30°	32°	34°	36°	38°
1057	1054	1047	1039	1026	1006	985	958	923	877	822	761	701	633	528	351	212	155	109	75
100%	100%	99%	98%	97%	95%	93%	91%	87%	83%	78%	72%	66%	60%	50%	33%	20%	15%	10%	7%

Beam angle 50%	Field angle 10%	Cutoff angle 2,5%	Intensity ratio in 120° cone	Intensity ratio in 90° cone
55.8°	72.2°	86.2°	99.6%	98.5%

Light planning

Luminaire budgetary diagram

LAMPS (number of lamps)
50

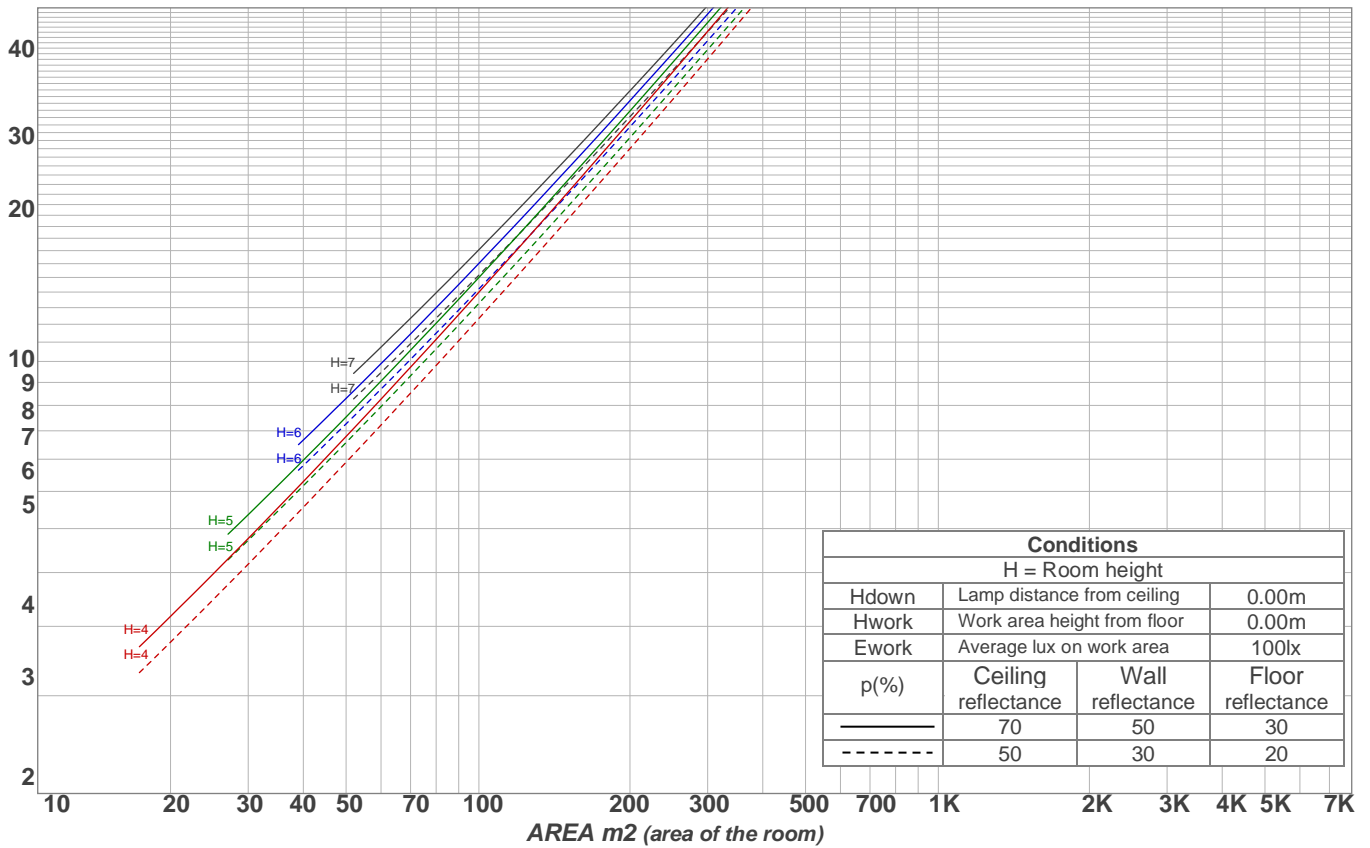

Luminaire budgetary diagram
AREA m2 (area of the room)
Coefficients of Utilization

Ceiling reflectance	80				70				50			30			10			0			
Wall reflectance	70	50	30	10	70	50	30	10	50	30	10	50	30	10	50	30	10	50	30	10	0
Floor reflectance	20	20	20	20	20	20	20	20	20	20	20	20	20	20	20	20	20	20	20	20	0
RCR	(RCR: Room Cavity Ratio)																				
	Room Values are expressed as percentage of Lumens delivered to the task surface																				
0	119	119	119	119	116	116	116	116	111	111	111	106	106	106	102	102	102	100	100	100	100
1	114	111	109	107	111	109	107	105	105	104	102	101	100	99	98	97	96	94	94	94	94
2	109	104	101	98	107	103	99	96	100	97	94	97	94	92	94	92	90	89	89	89	89
3	104	98	94	90	102	97	93	89	94	91	88	92	89	86	90	87	85	84	84	84	84
4	99	93	87	84	98	91	87	83	89	85	82	87	84	81	86	83	80	79	79	79	79
5	95	87	82	78	93	86	81	78	85	80	77	83	79	76	82	78	76	74	74	74	74
6	91	83	77	73	89	82	77	73	80	76	73	79	75	72	78	74	72	70	70	70	70
7	87	78	73	69	86	78	73	69	76	72	69	75	71	68	74	71	68	67	67	67	67
8	83	74	69	65	82	74	69	65	73	68	65	72	68	65	71	67	64	63	63	63	63
9	80	71	65	62	79	70	65	62	69	65	61	69	64	61	68	64	61	60	60	60	60
10	76	67	62	59	75	67	62	58	66	62	58	65	61	58	65	61	58	57	57	57	57

Zonal Lumen Summary

0°-10°	10°-20°	20°-30°	30°-40°	40°-50°	50°-60°	60°-70°	70°-80°	80°-90°
98.4 lm	261 lm	291 lm	90.5 lm	16.1 lm	3.92 lm	1.61 lm	1.19 lm	0.554 lm
90°-100°	100°-110°	110°-120°	120°-130°	130°-140°	140°-150°	150°-160°	160°-170°	170°-180°
0.000 lm	0.000 lm	0.000 lm	0.000 lm	0.000 lm	0.000 lm	0.000 lm	0.000 lm	0.000 lm

UGR

p Ceiling		70	70	50	50	30	70	70	50	50	30
p Walls		50	30	50	30	30	50	30	50	30	30
p Floor		20	20	20	20	20	20	20	20	20	20
Room size X Y		Viewing direction at right angles to lamp axis					Viewing direction parallel to lamp axis				
2H	2H	26.1	26.6	26.2	26.9	27.0	25.9	26.5	26.0	26.7	26.9
	3H	25.8	26.5	26.2	26.7	26.9	25.7	26.4	26.0	26.6	26.7
	4H	25.7	26.4	26.1	26.6	26.9	25.6	26.3	26.0	26.5	26.8
	6H	25.8	26.3	26.1	26.6	27.0	25.6	26.2	25.9	26.5	26.8
	8H	25.7	26.3	26.0	26.6	27.0	25.6	26.1	25.9	26.5	26.8
	12H	25.7	26.2	26.0	26.6	27.0	25.5	26.1	25.9	26.4	26.9
4H	2H	25.7	26.4	26.1	26.6	26.8	25.6	26.3	26.0	26.5	26.7
	3H	25.6	26.2	26.0	26.5	26.9	25.5	26.0	25.8	26.4	26.8
	4H	25.5	26.0	25.9	26.4	26.9	25.4	25.9	25.8	26.3	26.8
	6H	25.5	26.0	26.0	26.4	26.7	25.4	25.9	25.9	26.2	26.6
	8H	25.5	26.0	26.0	26.3	26.7	25.3	25.8	25.8	26.2	26.5
	12H	25.4	25.8	25.9	26.2	26.7	25.3	25.7	25.8	26.1	26.5
8H	4H	25.4	25.9	25.9	26.2	26.6	25.3	25.8	25.8	26.1	26.5
	6H	25.4	25.7	25.9	26.2	26.7	25.3	25.6	25.8	26.1	26.6
	8H	25.5	25.7	26.0	26.2	26.8	25.3	25.6	25.8	26.1	26.7
	12H	25.4	25.6	26.0	26.2	26.8	25.3	25.5	25.9	26.0	26.6
12H	4H	25.4	25.7	25.9	26.1	26.6	25.2	25.6	25.7	26.0	26.5
	6H	25.4	25.7	25.9	26.2	26.8	25.3	25.5	25.8	26.1	26.7
	8H	25.4	25.6	26.0	26.1	26.7	25.3	25.5	25.9	26.0	26.6
Corrected glare indices referring to 764 lm total luminous flux											