

Light efficiency:



Output: 1199 lm

Light quality:



Peak: 1608 cd

Power: 15.0 W



Beam angle

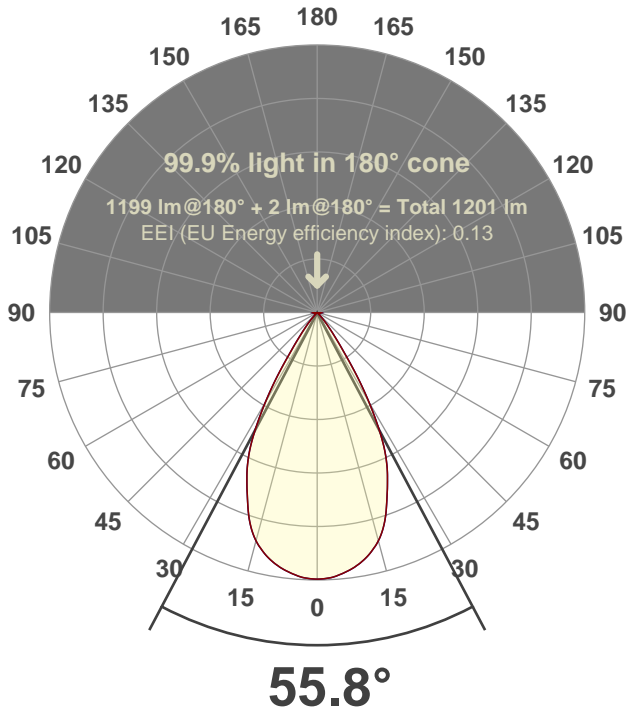

Test number:

CR4D-R-OR-C14-30k-55 (GRO-CZ20-WF-RD)

Luminaire Model:

Core 4" Open Deep Regress C14 30K 55°

Date and time:

6/14/2017 2:30:22 PM

LUM: 1199

Spectra

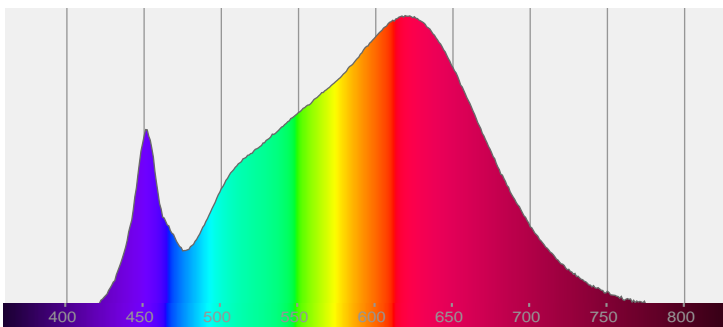

CRI: 92.8 (R1-R8)

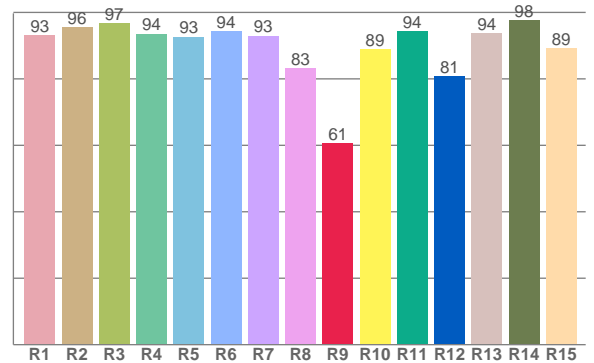

Color parameters

	Color rendering index	Red component	Color fidelity	Color gamut	Color quality scale	Color coordinate cie 1931	Color coordinate cie 1931	Color coordinate	Color coordinate	Color deviation from black body
	CRI	CRI R9	TM30 R _f	TM30 R _g	CQS	x	y	u	v	Δuv
	92.8	60.5	91.9	100.2	91.0	0.428	0.400	0.246	0.346	-0.0002

R_f 91.9
Fidelity index R_f

R_g 100.2
Gammut index R_g

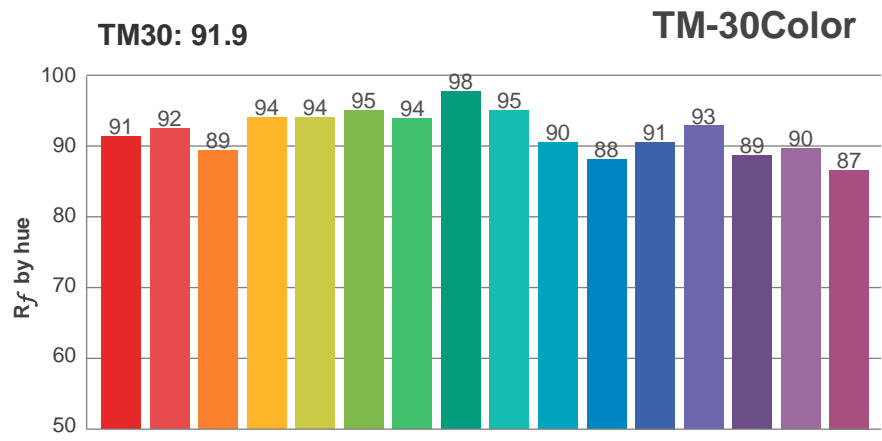

Hue Bin	R_f	Graphic shifts (%)	
		Chroma	Hue
1	91	-5%	-1%
2	92	-3%	3%
3	89	-1%	5%
4	94	0%	3%
5	94	0%	3%
6	95	3%	0%
7	94	-1%	-3%
8	98	0%	-1%
9	95	-2%	2%
10	90	-2%	5%
11	88	1%	8%
12	91	6%	2%
13	93	4%	-3%
14	89	5%	-8%
15	90	0%	-7%
16	87	-1%	-11%

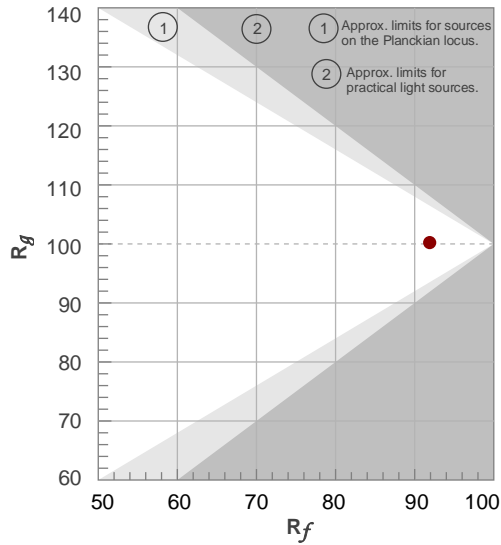

Color vector graphics

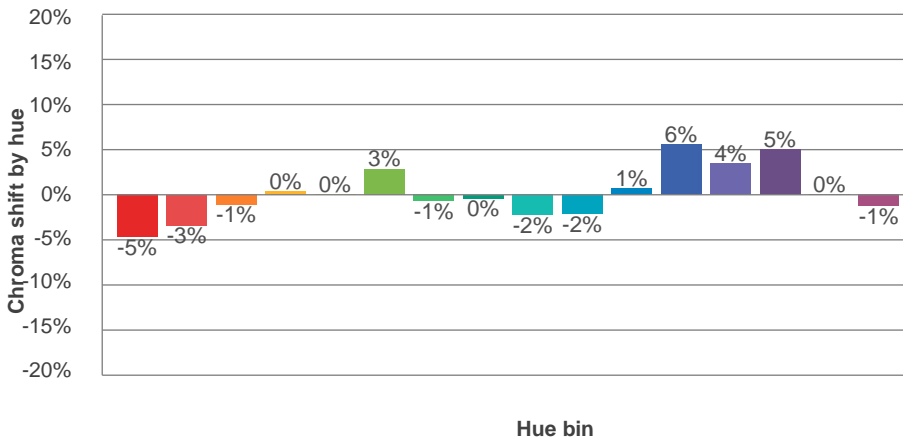
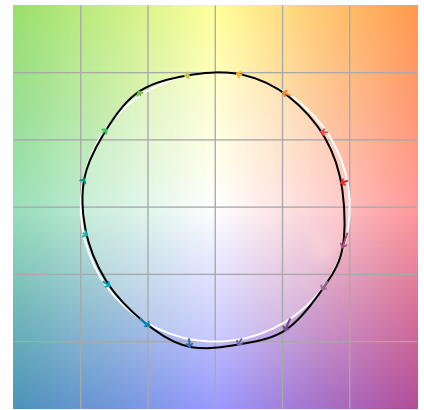

Color distortion

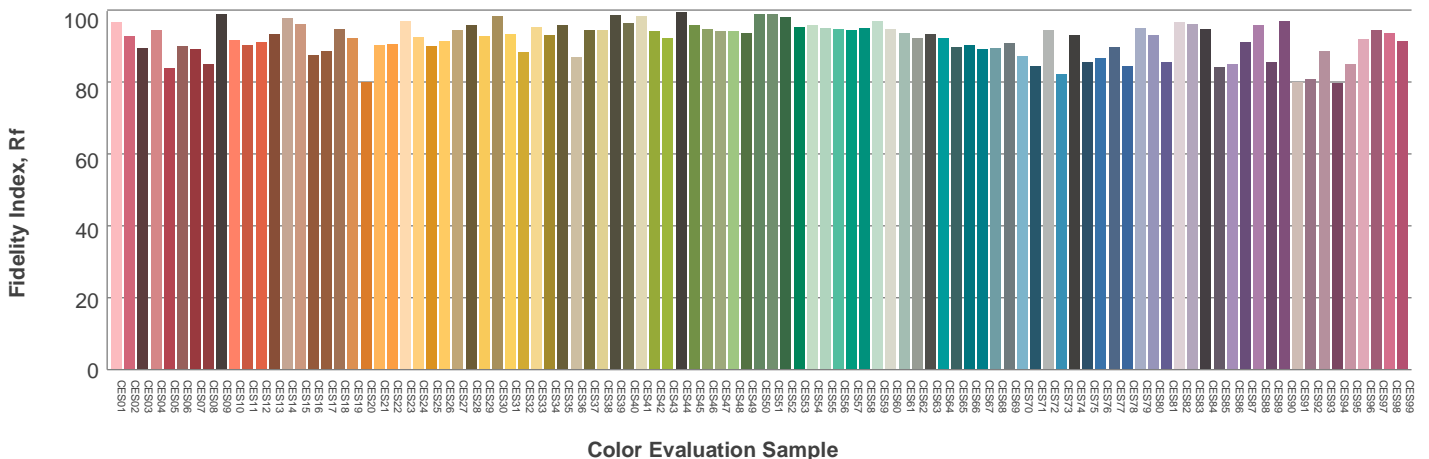

Beam details

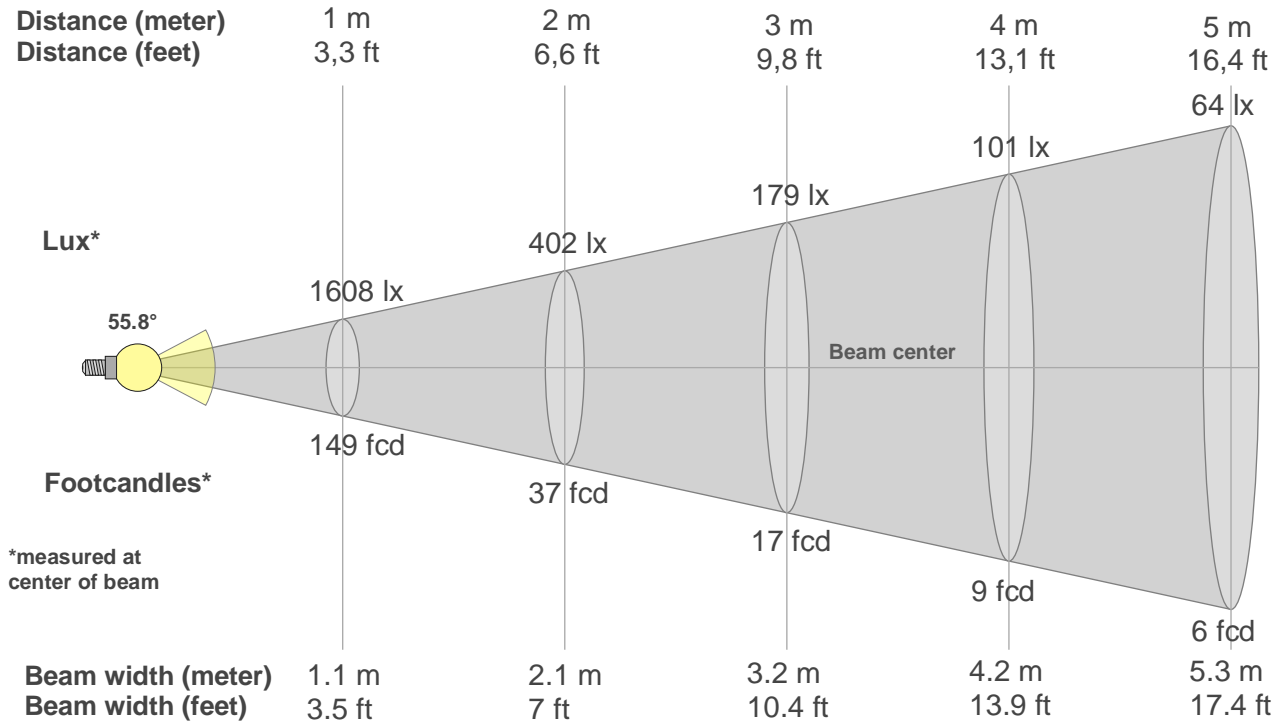

Beam intensities from 1-20m

1m	2m	3m	4m	5m	6m	7m	8m	9m	10m	11m	12m	13m	14m	15m	16m	17m	18m	19m	20m
3.3ft	6.6ft	9.8ft	13.1ft	16.4ft	19.7ft	23ft	26.2ft	29.5ft	32.8ft	36.1ft	39.4ft	42.7ft	45.9ft	49.2ft	52.5ft	55.8ft	59.1ft	62.3ft	65.6ft
1608lx	402lx	179lx	101lx	64lx	45lx	33lx	25lx	20lx	16lx	13lx	11lx	10lx	8lx	7lx	6lx	6lx	5lx	4lx	4lx
149.4fcd	37.4fcd	16.6fcd	9.3fcd	6fcd	4.2fcd	3fcd	2.3fcd	1.8fcd	1.5fcd	1.2fcd	1fcd	0.9fcd	0.8fcd	0.7fcd	0.6fcd	0.5fcd	0.5fcd	0.4fcd	0.4fcd

Intensities in 0° c-plane

0°	2°	4°	6°	8°	10°	12°	14°	16°	18°	20°	22°	24°	26°	28°	30°	32°	34°	36°	38°
1608	1605	1595	1578	1557	1530	1495	1452	1397	1322	1228	1134	1042	936	795	635	470	307	204	137
100%	100%	99%	98%	97%	95%	93%	90%	87%	82%	76%	71%	65%	58%	49%	39%	29%	19%	13%	9%

Intensities in 90° c-plane

0°	2°	4°	6°	8°	10°	12°	14°	16°	18°	20°	22°	24°	26°	28°	30°	32°	34°	36°	38°
1608	1605	1595	1578	1557	1530	1495	1452	1397	1322	1228	1134	1042	936	795	635	470	307	204	137
100%	100%	99%	98%	97%	95%	93%	90%	87%	82%	76%	71%	65%	58%	49%	39%	29%	19%	13%	9%

Intensities in 180° c-plane

0°	2°	4°	6°	8°	10°	12°	14°	16°	18°	20°	22°	24°	26°	28°	30°	32°	34°	36°	38°
1608	1605	1595	1578	1557	1530	1495	1452	1397	1322	1228	1134	1042	936	795	635	470	307	204	137
100%	100%	99%	98%	97%	95%	93%	90%	87%	82%	76%	71%	65%	58%	49%	39%	29%	19%	13%	9%

Intensities in 270° c-plane

0°	2°	4°	6°	8°	10°	12°	14°	16°	18°	20°	22°	24°	26°	28°	30°	32°	34°	36°	38°
1608	1605	1595	1578	1557	1530	1495	1452	1397	1322	1228	1134	1042	936	795	635	470	307	204	137
100%	100%	99%	98%	97%	95%	93%	90%	87%	82%	76%	71%	65%	58%	49%	39%	29%	19%	13%	9%

Beam angle 50%	Field angle 10%	Cutoff angle 2,5%	Intensity ratio in 120° cone	Intensity ratio in 90° cone
55.8°	74.4°	87.6°	99.6%	98.6%

Light planning

Luminaire budgetary diagram

LAMPS (number of lamps)
50

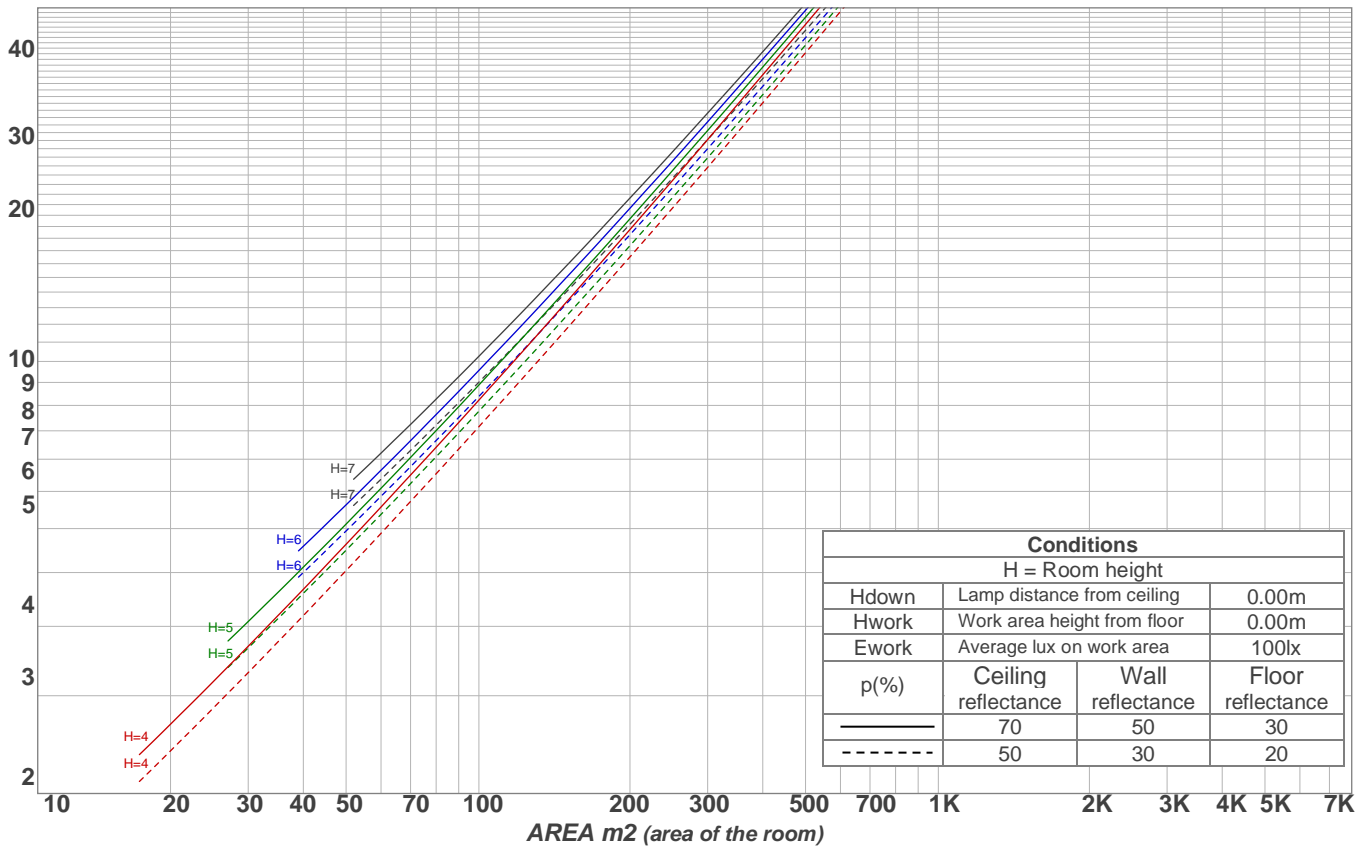

Luminaire budgetary diagram
AREA m2 (area of the room)
Coefficients of Utilization

Ceiling reflectance	80				70				50			30			10			0			
Wall reflectance	70	50	30	10	70	50	30	10	50	30	10	50	30	10	50	30	10	50	30	10	0
Floor reflectance	20	20	20	20	20	20	20	20	20	20	20	20	20	20	20	20	20	20	20	20	0
RCR	(RCR: Room Cavity Ratio)																				
	Room Values are expressed as percentage of Lumens delivered to the task surface																				
0	119	119	119	119	116	116	116	116	111	111	111	106	106	106	102	102	102	100	100	100	
1	114	111	109	107	111	109	107	105	105	103	102	101	100	99	98	97	96	94	94	94	
2	109	104	100	97	107	103	99	96	99	97	94	96	94	92	94	92	90	89	89	89	
3	104	98	93	90	102	97	92	89	94	90	87	92	89	86	89	87	85	83	83	83	
4	99	92	87	83	97	91	86	83	89	85	82	87	84	81	85	82	80	78	78	78	
5	95	87	81	78	93	86	81	77	84	80	76	83	79	76	81	78	75	74	74	74	
6	90	82	77	73	89	81	76	72	80	75	72	79	74	71	77	74	71	70	70	70	
7	86	78	72	68	85	77	72	68	76	71	68	75	70	67	74	70	67	66	66	66	
8	82	74	68	64	81	73	68	64	72	67	64	71	67	64	70	66	63	62	62	62	
9	79	70	64	61	78	69	64	61	69	64	60	68	63	60	67	63	60	59	59	59	
10	76	67	61	58	75	66	61	57	65	61	57	65	60	57	64	60	57	56	56	56	

Zonal Lumen Summary

0°-10°	10°-20°	20°-30°	30°-40°	40°-50°	50°-60°	60°-70°	70°-80°	80°-90°
150 lm	395 lm	440 lm	178 lm	27.8 lm	4.92 lm	1.42 lm	1.11 lm	0.838 lm
90°-100°	100°-110°	110°-120°	120°-130°	130°-140°	140°-150°	150°-160°	160°-170°	170°-180°
0.000 lm	0.000 lm	0.000 lm	0.000 lm	0.000 lm	0.000 lm	0.000 lm	0.000 lm	0.000 lm

UGR

p Ceiling		70	70	50	50	30	70	70	50	50	30
p Walls		50	30	50	30	30	50	30	50	30	30
p Floor		20	20	20	20	20	20	20	20	20	20
Room size X Y		Viewing direction at right angles to lamp axis					Viewing direction parallel to lamp axis				
2H	2H	29.9	30.5	30.0	30.7	30.9	29.9	30.5	30.0	30.7	30.9
	3H	29.6	30.3	30.0	30.5	30.7	29.6	30.3	30.0	30.5	30.7
	4H	29.6	30.2	29.9	30.5	30.7	29.6	30.2	29.9	30.5	30.7
	6H	29.6	30.1	29.9	30.4	30.8	29.6	30.1	29.9	30.4	30.8
	8H	29.5	30.1	29.8	30.4	30.8	29.5	30.1	29.8	30.4	30.8
	12H	29.5	30.0	29.8	30.3	30.8	29.5	30.0	29.8	30.3	30.8
4H	2H	29.5	30.2	29.9	30.5	30.7	29.5	30.2	29.9	30.5	30.7
	3H	29.4	30.0	29.8	30.3	30.7	29.4	30.0	29.8	30.3	30.7
	4H	29.3	29.8	29.7	30.2	30.7	29.3	29.8	29.7	30.2	30.7
	6H	29.2	29.8	29.7	30.1	30.4	29.2	29.8	29.7	30.1	30.4
	8H	29.2	29.7	29.7	30.0	30.4	29.2	29.7	29.7	30.0	30.4
	12H	29.1	29.5	29.6	29.9	30.4	29.1	29.5	29.6	29.9	30.4
8H	4H	29.2	29.7	29.7	30.0	30.4	29.2	29.7	29.7	30.0	30.4
	6H	29.1	29.5	29.6	29.9	30.4	29.1	29.5	29.6	29.9	30.4
	8H	29.1	29.4	29.7	29.9	30.5	29.1	29.4	29.7	29.9	30.5
	12H	29.1	29.3	29.7	29.8	30.4	29.1	29.3	29.7	29.8	30.4
12H	4H	29.1	29.5	29.6	29.9	30.4	29.1	29.5	29.6	29.9	30.4
	6H	29.1	29.4	29.6	29.9	30.5	29.1	29.4	29.6	29.9	30.5
	8H	29.1	29.3	29.7	29.8	30.4	29.1	29.3	29.7	29.8	30.4
Corrected glare indices referring to 1199 lm total luminous flux											