

Light efficiency:



Output: 497 lm

Light quality:



Peak: 11368 cd

Power: 8.3 W

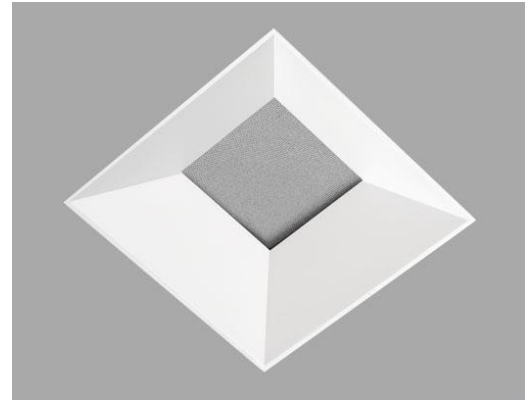

Beam angle

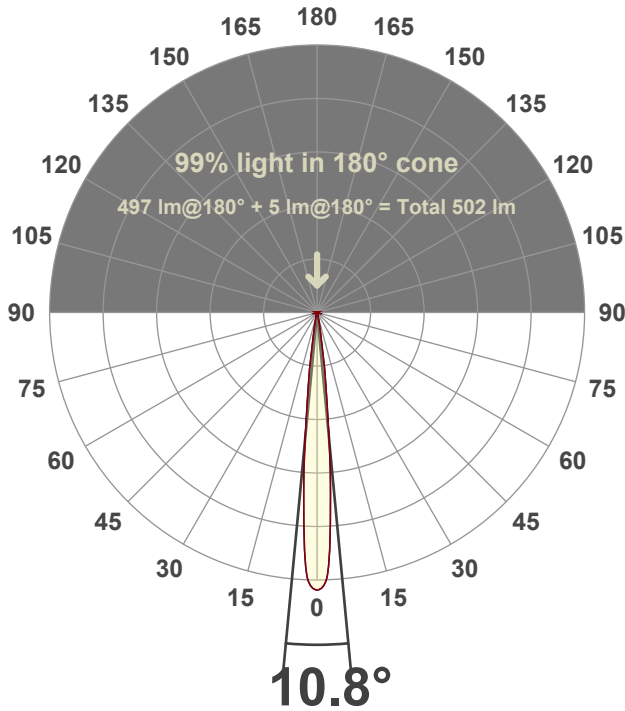

Test number:

CR3D-SF-DR-C8-30K-10

Luminaire Model:

Core 3" Square Deep Regress C8-30K-10°

Date and time:

4/6/2026 1:01:22 PM

LUM: 497



\*Variation due to source size, bezel geometry, or secondary optics

Spectra

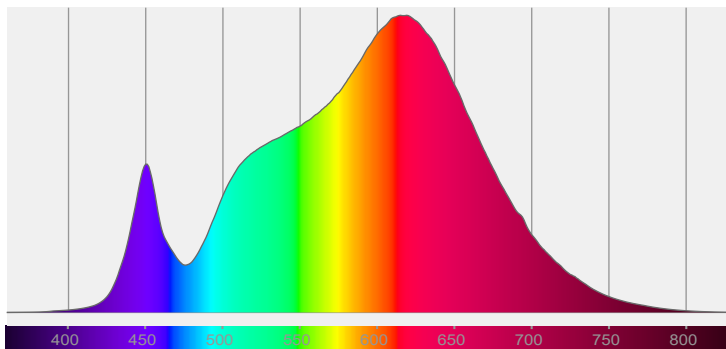

CRI: 92.4 (R1-R8)

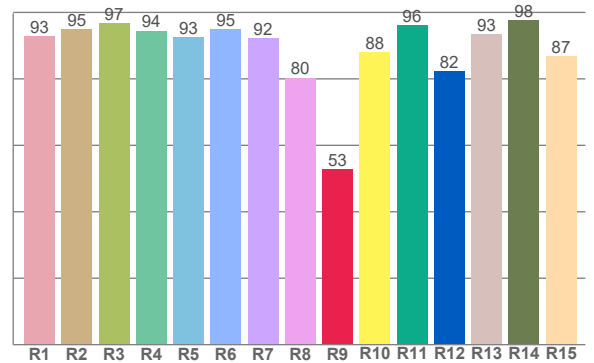

Color parameters

	Color rendering index	Red component	Color fidelity	Color gamut	Color quality scale	Color coordinate cie 1931	Color coordinate cie 1931	Color coordinate	Color coordinate	Color deviation from black body
	CRI	CRI R9	TM30 R <sub>f</sub>	TM30 R <sub>g</sub>	CQS	x	y	u	v	Δuv
	92.4	52.9	91.9	100.2	90.8	0.437	0.407	0.249	0.348	0.0013

**$R_f$  91.9**  
Fidelity index  $R_f$

---

**$R_g$  100.2**  
Gammut index  $R_g$

TM30: 91.9

TM-30Color

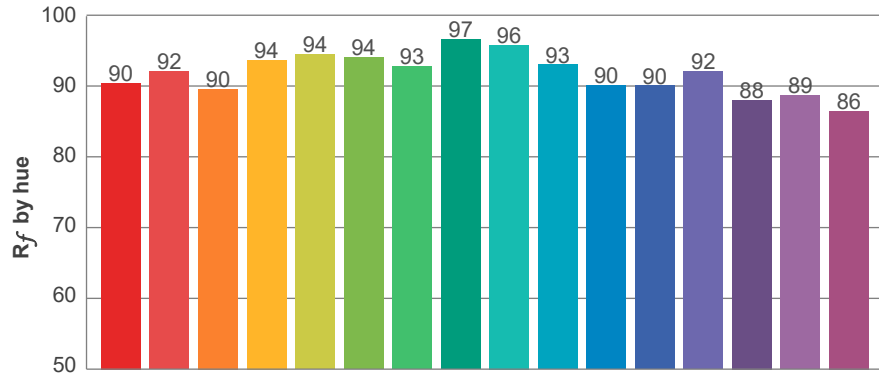

Hue Bin	$R_f$	Graphic shifts (%)	
		Chroma	Hue
1	90	-5%	-1%
2	92	-4%	3%
3	90	-1%	5%
4	94	1%	4%
5	94	1%	3%
6	94	4%	0%
7	93	0%	-4%
8	97	1%	-2%
9	96	-2%	0%
10	93	-3%	3%
11	90	0%	7%
12	90	4%	2%
13	92	4%	-4%
14	88	4%	-9%
15	89	0%	-8%
16	86	-2%	-11%

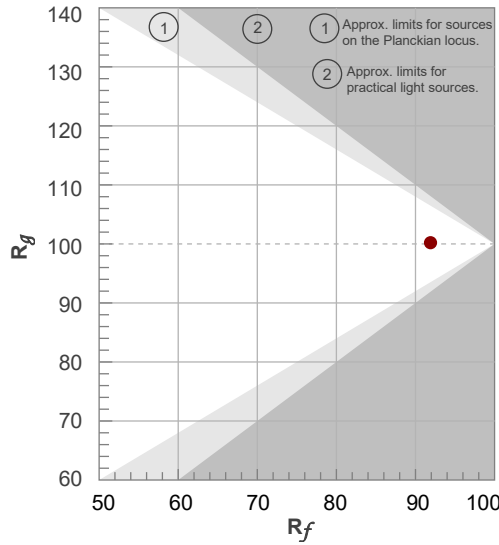

Color vector graphics

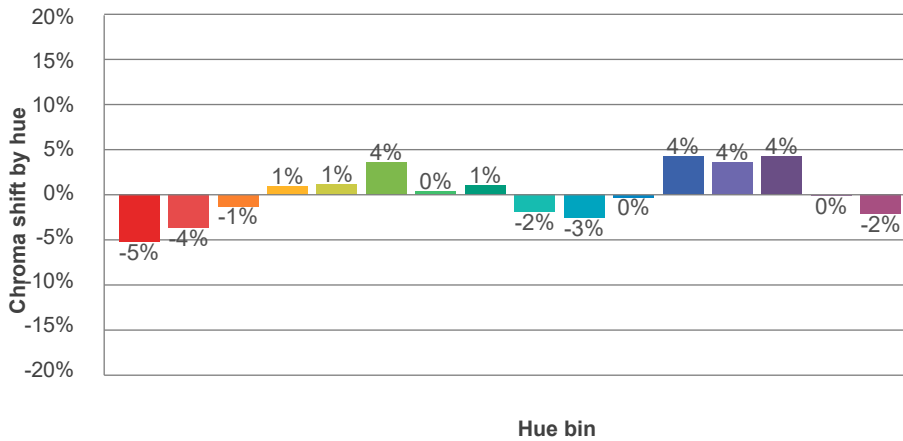
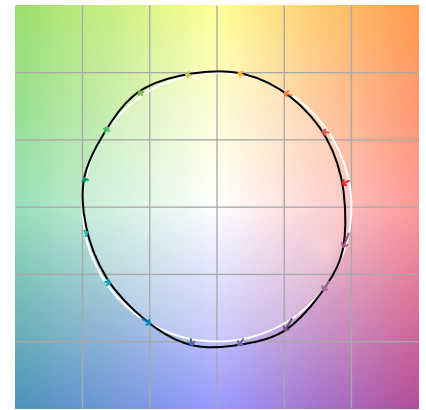

Color distortion

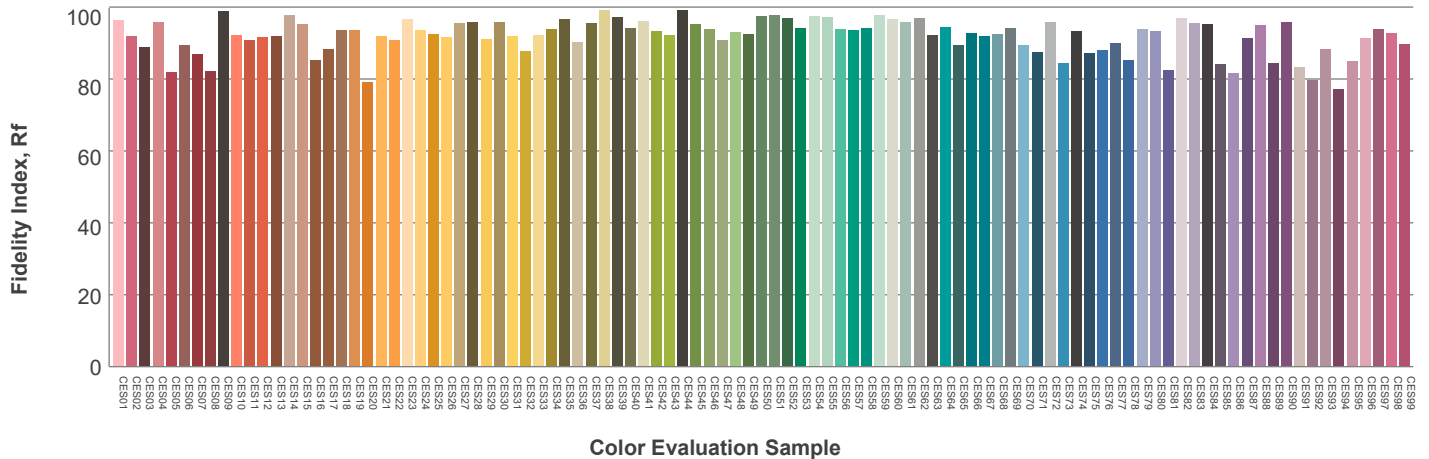

### Beam details

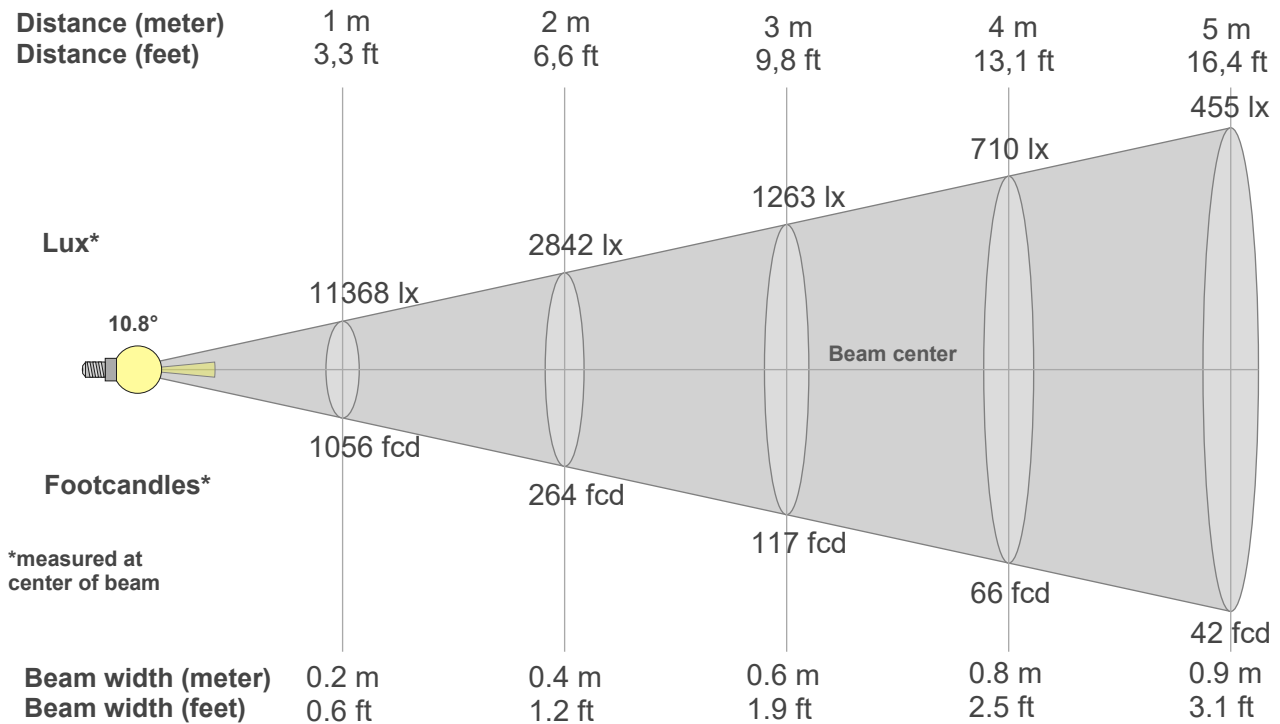

#### Beam intensities from 1-20m

1m	2m	3m	4m	5m	6m	7m	8m	9m	10m	11m	12m	13m	14m	15m	16m	17m	18m	19m	20m
3.3ft	6.6ft	9.8ft	13.1ft	16.4ft	19.7ft	23ft	26.2ft	29.5ft	32.8ft	36.1ft	39.4ft	42.7ft	45.9ft	49.2ft	52.5ft	55.8ft	59.1ft	62.3ft	65.6ft
11368lx	2842lx	1263lx	710lx	455lx	316lx	232lx	178lx	140lx	114lx	94lx	79lx	67lx	58lx	51lx	44lx	39lx	35lx	31lx	28lx
1056.1fcd	264fcd	117.3fcd	66fcd	42.2fcd	29.3fcd	21.6fcd	16.5fcd	13fcd	10.6fcd	8.7fcd	7.3fcd	6.2fcd	5.4fcd	4.7fcd	4.1fcd	3.7fcd	3.3fcd	2.9fcd	2.6fcd

#### Intensities in 0° c-plane

0°	1°	2°	3°	4°	5°	6°	7°	8°	9°	10°	11°	12°	13°	14°	15°	16°	17°	18°	19°
11.4k	11.4k	11.4k	9.8k	8.1k	6.4k	4.6k	3.0k	2.1k	1.2k	0.8k	0.5k	0.3k	0.3k	0.2k	0.2k	0.1k	0.1k	0.1k	0.1k
100%	100%	100%	86%	71%	56%	41%	26%	18%	10%	7%	5%	3%	2%	2%	1%	1%	1%	1%	1%

#### Intensities in 90° c-plane

0°	1°	2°	3°	4°	5°	6°	7°	8°	9°	10°	11°	12°	13°	14°	15°	16°	17°	18°	19°
11.4k	11.4k	11.4k	9.8k	8.1k	6.4k	4.6k	3.0k	2.1k	1.2k	0.8k	0.5k	0.3k	0.3k	0.2k	0.2k	0.1k	0.1k	0.1k	0.1k
100%	100%	100%	86%	71%	56%	41%	26%	18%	10%	7%	5%	3%	2%	2%	1%	1%	1%	1%	1%

#### Intensities in 180° c-plane

0°	1°	2°	3°	4°	5°	6°	7°	8°	9°	10°	11°	12°	13°	14°	15°	16°	17°	18°	19°
11.4k	11.4k	11.4k	9.8k	8.1k	6.4k	4.6k	3.0k	2.1k	1.2k	0.8k	0.5k	0.3k	0.3k	0.2k	0.2k	0.1k	0.1k	0.1k	0.1k
100%	100%	100%	86%	71%	56%	41%	26%	18%	10%	7%	5%	3%	2%	2%	1%	1%	1%	1%	1%

#### Intensities in 270° c-plane

0°	1°	2°	3°	4°	5°	6°	7°	8°	9°	10°	11°	12°	13°	14°	15°	16°	17°	18°	19°
11.4k	11.4k	11.4k	9.8k	8.1k	6.4k	4.6k	3.0k	2.1k	1.2k	0.8k	0.5k	0.3k	0.3k	0.2k	0.2k	0.1k	0.1k	0.1k	0.1k
100%	100%	100%	86%	71%	56%	41%	26%	18%	10%	7%	5%	3%	2%	2%	1%	1%	1%	1%	1%

Beam angle 50%	Field angle 10%	Cutoff angle 2,5%	Intensity ratio in 120° cone	Intensity ratio in 90° cone
10.8°	18.1°	25.2°	99.2%	98.8%

LAMPS (number of lamps)  
50

### Light planning Luminaire budgetary diagram

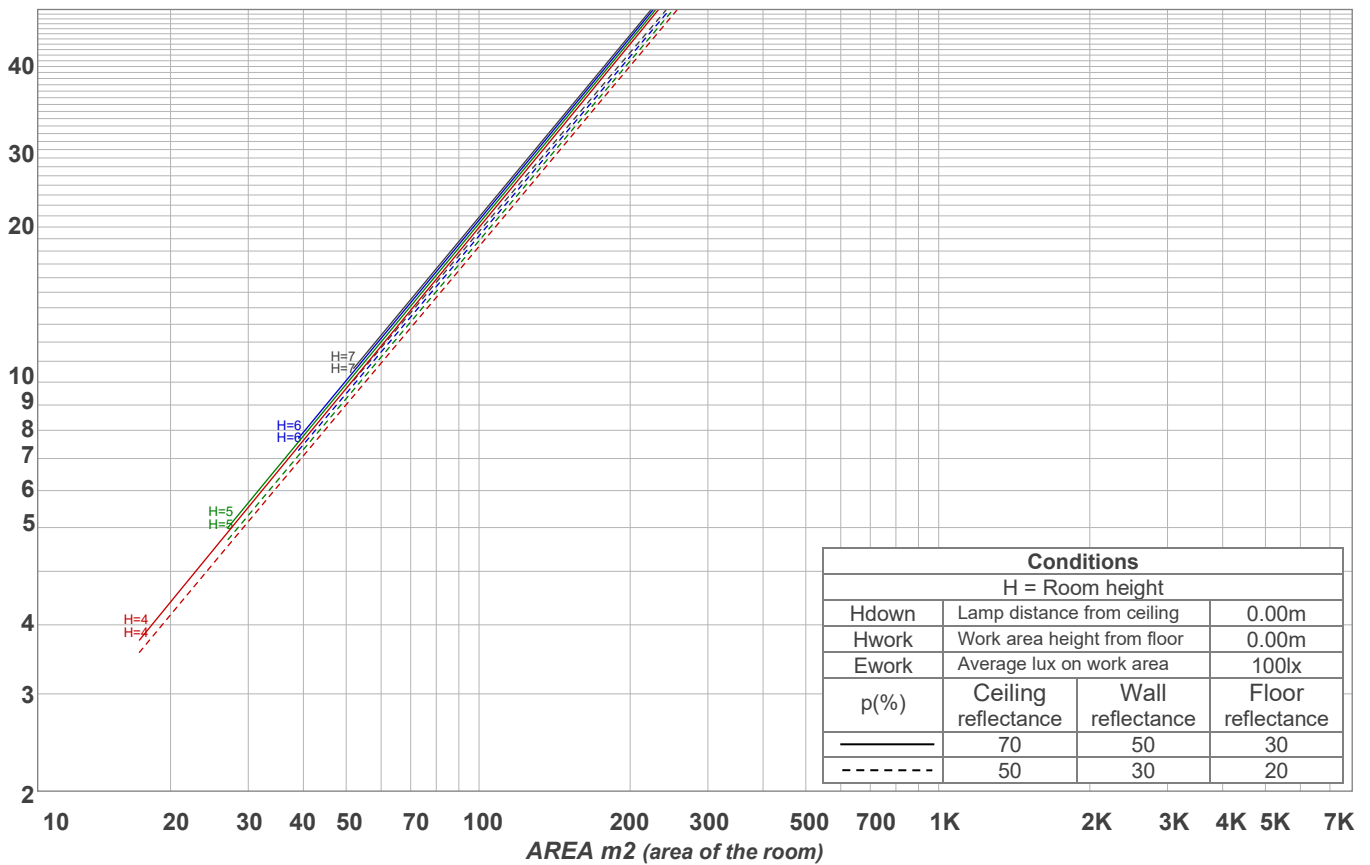

### Luminaire budgetary diagram AREA m2 (area of the room) Coefficients of Utilization

Ceiling reflectance	80				70				50			30			10			0			
Wall reflectance	70	50	30	10	70	50	30	10	50	30	10	50	30	10	50	30	10	50	30	10	0
Floor reflectance	20	20	20	20	20	20	20	20	20	20	20	20	20	20	20	20	20	20	20	20	0
RCR	(RCR: Room Cavity Ratio)																				
	Room Values are expressed as percentage of Lumens delivered to the task surface																				
0	119	119	119	119	116	116	116	116	111	111	111	106	106	106	102	102	102	100	100		
1	116	114	113	111	114	112	111	109	108	107	106	104	104	103	101	101	100	98	98		
2	113	110	108	106	111	109	107	105	106	104	103	103	102	100	100	99	98	97	97		
3	111	107	105	102	109	106	104	102	104	102	100	102	100	99	99	98	97	96	96		
4	109	105	102	100	107	104	101	99	102	100	98	100	98	97	99	97	96	95	95		
5	107	103	100	98	106	102	99	97	100	98	96	99	97	96	98	96	95	94	94		
6	105	101	98	96	104	100	98	96	99	97	95	98	96	94	97	95	94	93	93		
7	104	99	97	95	103	99	96	94	98	96	94	97	95	93	96	94	93	92	92		
8	103	98	95	93	102	98	95	93	97	95	93	96	94	93	95	94	92	91	91		
9	101	97	94	92	101	97	94	92	96	94	92	95	93	92	95	93	92	91	91		
10	100	96	93	92	100	96	93	91	95	93	91	95	93	91	94	92	91	90	90		

### Zonal Lumen Summary

0°-10°	10°-20°	20°-30°	30°-40°	40°-50°	50°-60°	60°-70°	70°-80°	80°-90°
397 lm	55.8 lm	22.7 lm	12.5 lm	4.59 lm	0.904 lm	1.01 lm	1.19 lm	1.54 lm
90°-100°	100°-110°	110°-120°	120°-130°	130°-140°	140°-150°	150°-160°	160°-170°	170°-180°
0.000 lm	0.000 lm	0.000 lm	0.000 lm	0.000 lm	0.000 lm	0.000 lm	0.000 lm	0.000 lm