

Light efficiency:



Output: 2646 lm

Light quality:



Peak: 16324 cd

Power: 28.5 W



Beam angle

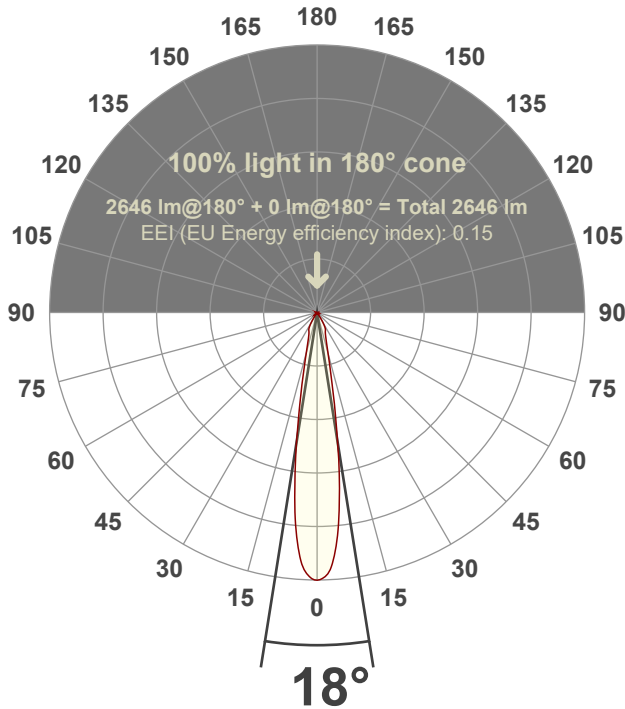

Test number:

MSC-H-L-C24-30k-18°

Luminaire Model:

Mosaic Large Accent Head-C24-30k-18°

Date and time:

8/29/2022 2:43:33 PM

LUM: 2646

Spectra

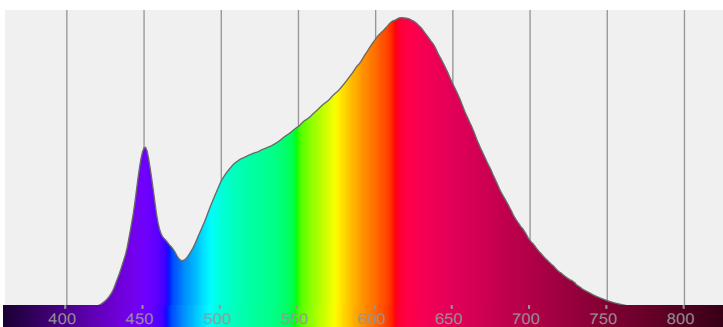

CRI: 93.7 (R1-R8)

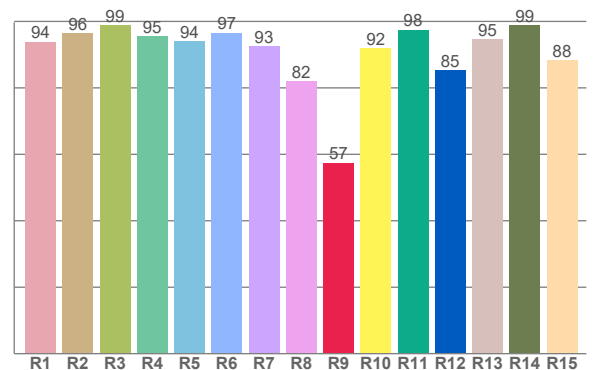

Color parameters

	Color rendering index	Red component	Color fidelity	Color gamut	Color quality scale	Color coordinate cie 1931	Color coordinate cie 1931	Color coordinate	Color coordinate	Color deviation from black body
	CRI	CRI R9	TM30 R _f	TM30 R _g	CQS	x	y	u	v	Δuv
	93.7	57.5	93.1	99.6	92.2	0.432	0.405	0.247	0.347	0.0012

R_f 93.1

Fidelity index R_f

R_g 99.6

Gammut index R_g

TM30: 93.1

TM-30Color

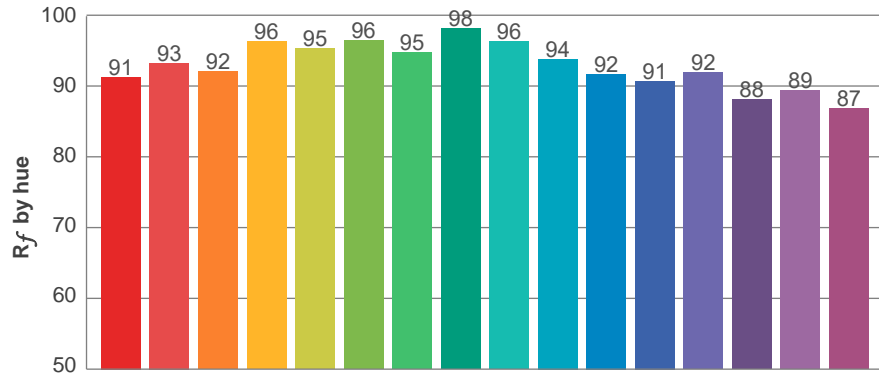

Hue Bin	R _f	Graphic shifts (%)	
		Chroma	Hue
1	91	-5%	-1%
2	93	-3%	2%
3	92	-1%	4%
4	96	0%	2%
5	95	-1%	2%
6	96	2%	0%
7	95	-1%	-2%
8	98	1%	0%
9	96	-1%	1%
10	94	-1%	3%
11	92	1%	5%
12	91	5%	-1%
13	92	3%	-5%
14	88	3%	-9%
15	89	-1%	-7%
16	87	-2%	-10%

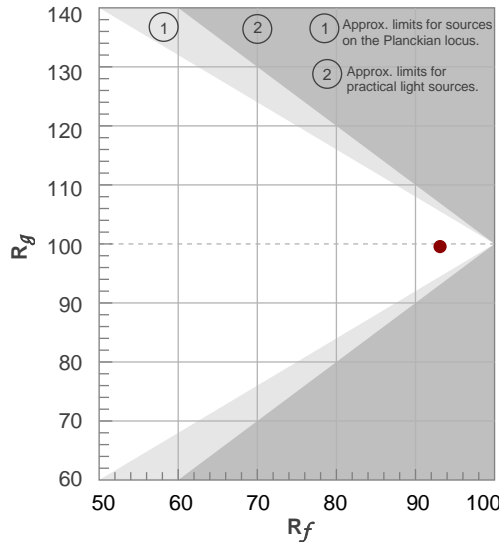

Color vector graphics

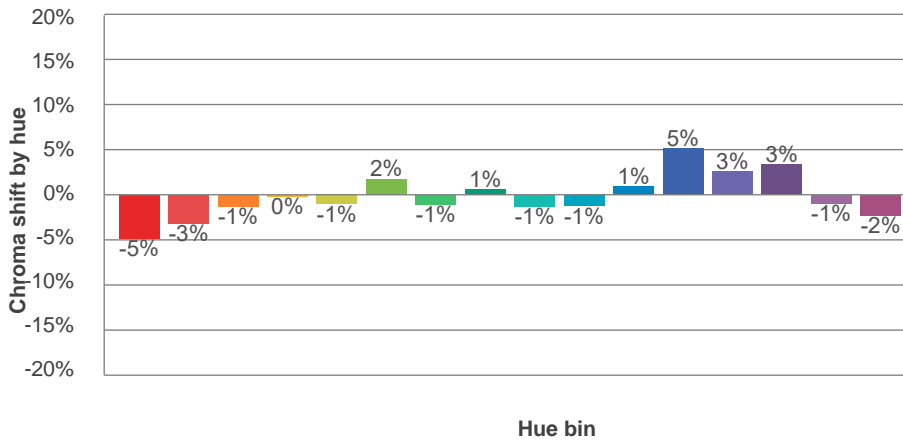
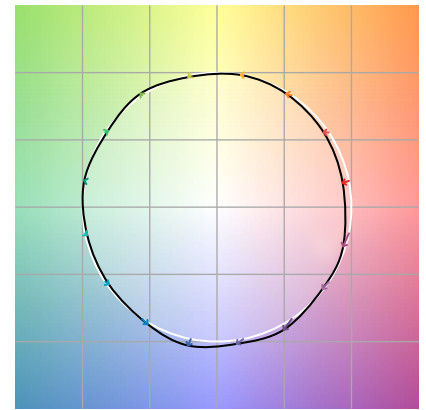

Color distortion

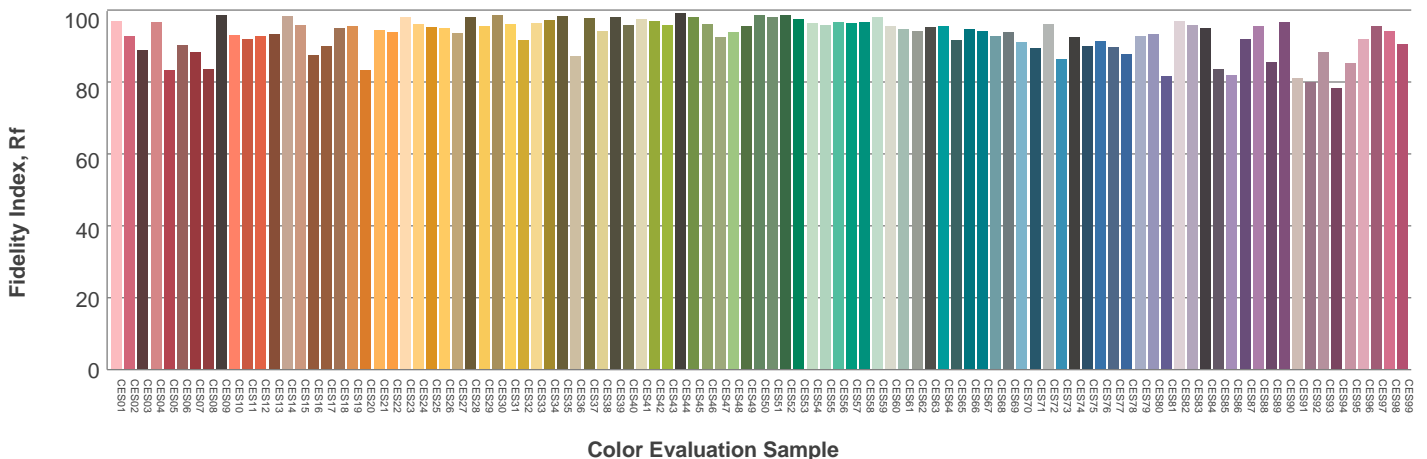

Beam details

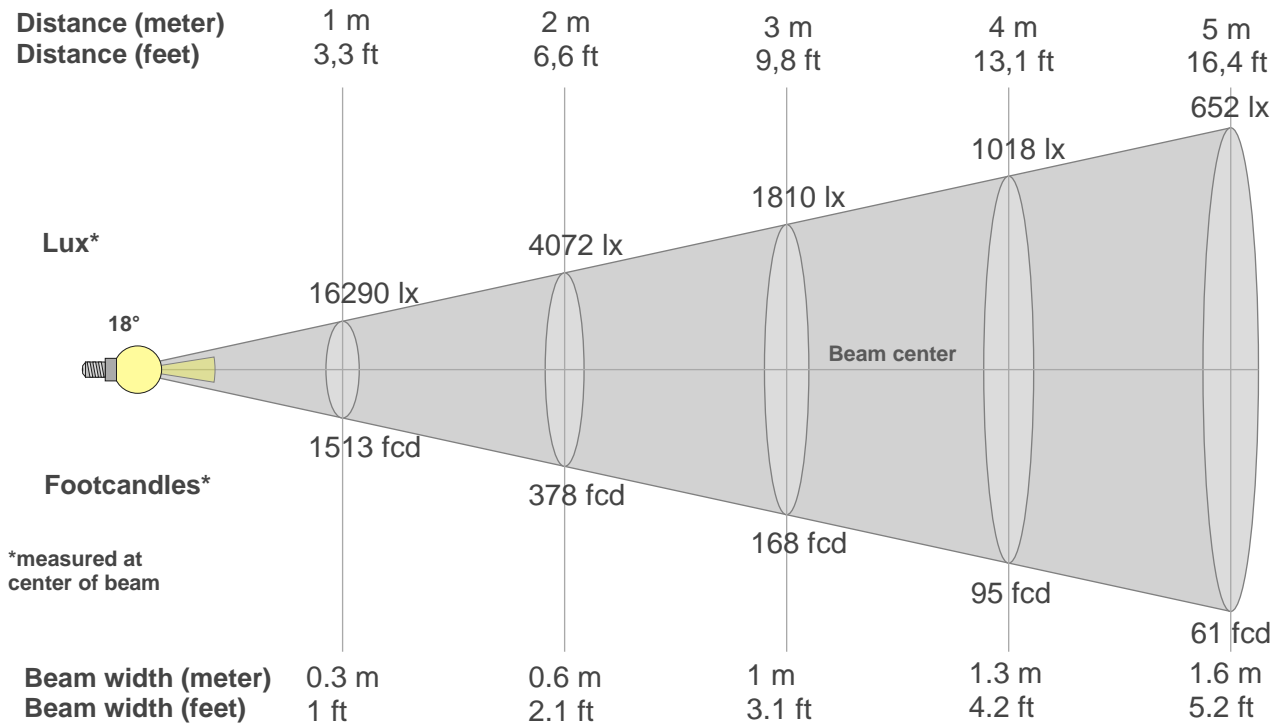

Beam intensities from 1-20m

1m	2m	3m	4m	5m	6m	7m	8m	9m	10m	11m	12m	13m	14m	15m	16m	17m	18m	19m	20m
3.3ft	6.6ft	9.8ft	13.1ft	16.4ft	19.7ft	23ft	26.2ft	29.5ft	32.8ft	36.1ft	39.4ft	42.7ft	45.9ft	49.2ft	52.5ft	55.8ft	59.1ft	62.3ft	65.6ft
16290lx	4072lx	1810lx	1018lx	652lx	452lx	332lx	255lx	201lx	163lx	135lx	113lx	96lx	83lx	72lx	64lx	56lx	50lx	45lx	41lx
1513.4fcd	378.3fcd	168.2fcd	94.6fcd	60.5fcd	42fcd	30.9fcd	23.6fcd	18.7fcd	15.1fcd	12.5fcd	10.5fcd	9fcd	7.7fcd	6.7fcd	5.9fcd	5.2fcd	4.7fcd	4.2fcd	3.8fcd

Intensities in 0° c-plane

0°	1°	2°	3°	4°	5°	6°	7°	8°	9°	10°	11°	12°	13°	14°	15°	16°	17°	18°	19°
16.3K	16.3K	16.0K	15.7K	14.8K	13.9K	12.7K	11.2K	9.7K	8.2K	6.6K	5.5K	4.5K	3.7K	3.2K	2.6K	2.3K	2.0K	1.9K	1.7K
100%	100%	98%	96%	91%	85%	78%	69%	60%	50%	41%	34%	28%	23%	19%	16%	14%	13%	11%	10%

Intensities in 90° c-plane

0°	1°	2°	3°	4°	5°	6°	7°	8°	9°	10°	11°	12°	13°	14°	15°	16°	17°	18°	19°
16.3K	16.3K	16.0K	15.7K	14.8K	13.9K	12.7K	11.2K	9.7K	8.2K	6.6K	5.5K	4.5K	3.7K	3.2K	2.6K	2.3K	2.0K	1.9K	1.7K
100%	100%	98%	96%	91%	85%	78%	69%	60%	50%	41%	34%	28%	23%	19%	16%	14%	13%	11%	10%

Intensities in 180° c-plane

0°	1°	2°	3°	4°	5°	6°	7°	8°	9°	10°	11°	12°	13°	14°	15°	16°	17°	18°	19°
16.3K	16.3K	16.0K	15.6K	15.0K	13.9K	12.8K	11.2K	9.7K	8.2K	6.8K	5.5K	4.6K	3.6K	3.1K	2.6K	2.3K	2.0K	1.8K	1.7K
100%	100%	98%	96%	92%	85%	78%	69%	59%	50%	41%	34%	28%	22%	19%	16%	14%	12%	11%	10%

Intensities in 270° c-plane

0°	1°	2°	3°	4°	5°	6°	7°	8°	9°	10°	11°	12°	13°	14°	15°	16°	17°	18°	19°
16.3K	16.3K	16.0K	15.6K	15.0K	13.9K	12.8K	11.2K	9.7K	8.2K	6.8K	5.5K	4.6K	3.6K	3.1K	2.6K	2.3K	2.0K	1.8K	1.7K
100%	100%	98%	96%	92%	85%	78%	69%	59%	50%	41%	34%	28%	22%	19%	16%	14%	12%	11%	10%

Beam angle 50%	Field angle 10%	Cutoff angle 2,5%	Intensity ratio in 120° cone	Intensity ratio in 90° cone
18°	38.5°	67.2°	99.4%	99.1%

LAMPS (number of lamps)
50

Light planning Luminaire budgetary diagram

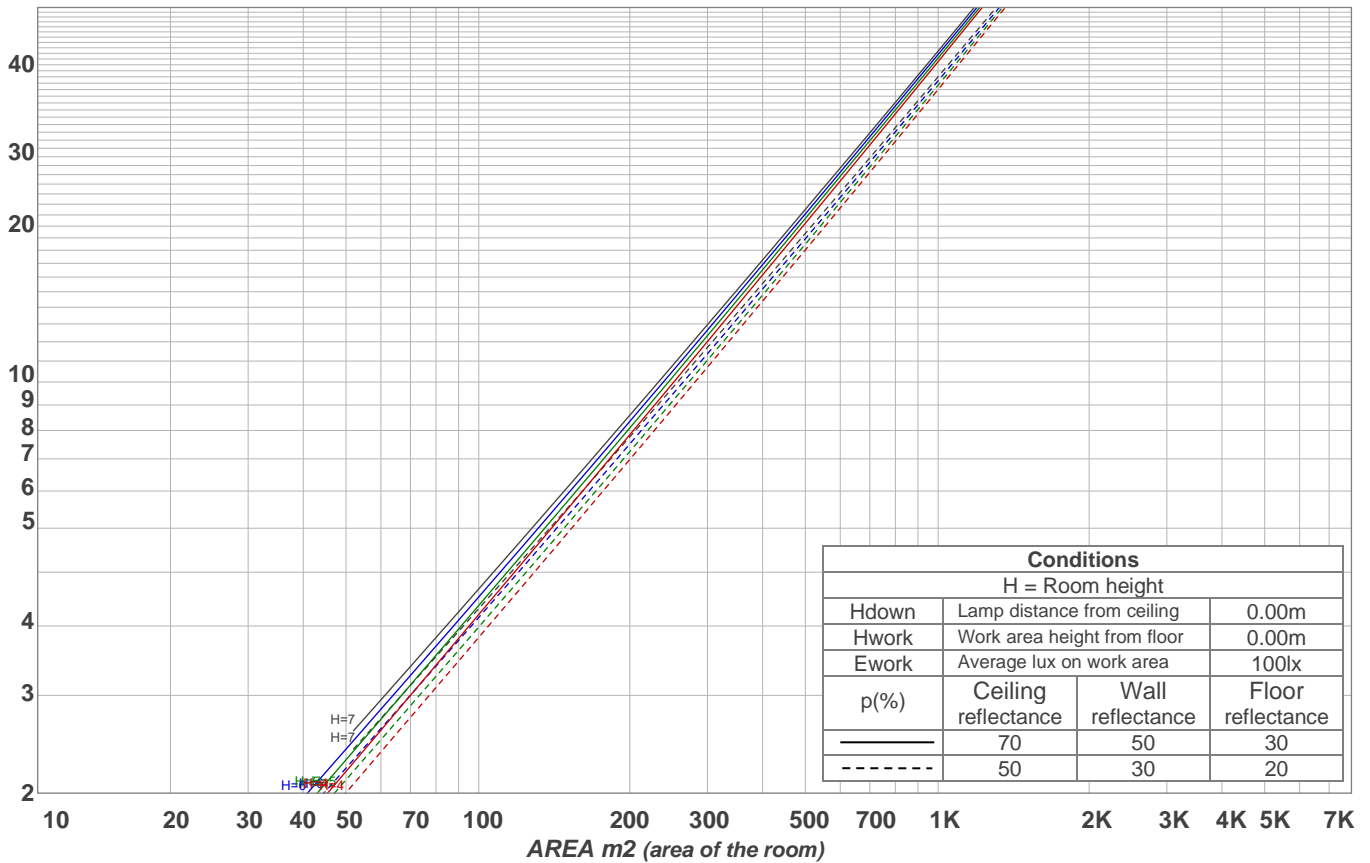

Luminaire budgetary diagram AREA m2 (area of the room) Coefficients of Utilization

Ceiling reflectance	80				70				50			30			10			0
Wall reflectance	70	50	30	10	70	50	30	10	50	30	10	50	30	10	50	30	10	0
Floor reflectance	20	20	20	20	20	20	20	20	20	20	20	20	20	20	20	20	20	0
RCR	(RCR: Room Cavity Ratio) Room Values are expressed as percentage of Lumens delivered to the task surface																	
0	119	119	119	119	116	116	116	116	111	111	111	106	106	106	102	102	102	100
1	115	113	111	109	112	111	109	107	107	105	104	103	102	101	100	99	98	96
2	111	107	104	102	109	106	103	101	103	100	98	100	98	96	97	96	94	93
3	107	103	99	96	106	101	98	95	99	96	94	97	94	92	94	93	91	90
4	104	99	95	91	102	97	94	91	96	92	90	94	91	89	92	90	88	87
5	101	95	91	88	99	94	90	87	92	89	87	91	88	86	90	87	85	84
6	98	92	87	84	97	91	87	84	90	86	84	88	85	83	87	85	82	81
7	95	89	84	81	94	88	84	81	87	83	81	86	83	80	85	82	80	79
8	93	86	82	79	92	85	81	79	84	81	78	84	80	78	83	80	78	77
9	90	83	79	76	89	83	79	76	82	79	76	81	78	76	81	78	76	75
10	88	81	77	74	87	81	77	74	80	77	74	79	76	74	79	76	74	73

Zonal Lumen Summary

0°-10°	10°-20°	20°-30°	30°-40°	40°-50°	50°-60°	60°-70°	70°-80°	80°-90°
1080 lm	810 lm	548 lm	183 lm	4.48 lm	3.80 lm	4.19 lm	5.44 lm	7.21 lm
90°-100°	100°-110°	110°-120°	120°-130°	130°-140°	140°-150°	150°-160°	160°-170°	170°-180°
0.000 lm	0.000 lm	0.000 lm	0.000 lm	0.000 lm	0.000 lm	0.000 lm	0.000 lm	0.000 lm