

Light efficiency:

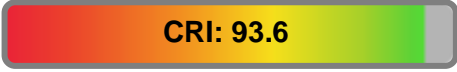

Output: 620 lm

Light quality:



Peak: 1498 cd

Power: 10.1 W

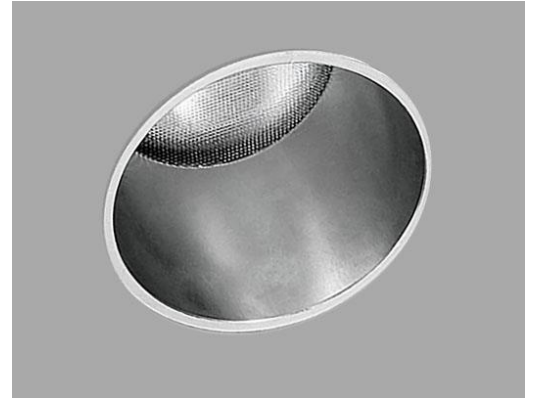

Beam angle

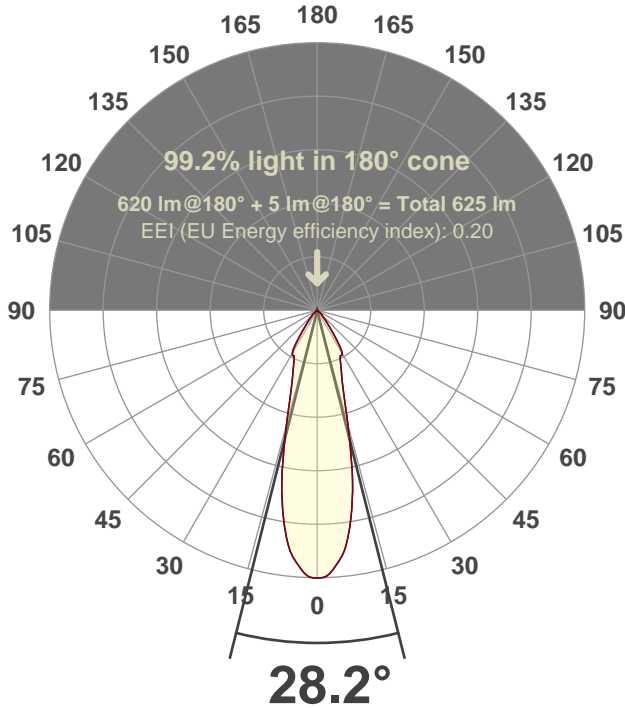

Test number:

SCOD-R-DR-T7-2765-30°-CLEAR ANODIZE-Rev1

Luminaire Model:

Scope Original 2.5" Round Deep Regress Downlight-T7-TW2765-30°

Date and time:

6/2/2021 7:49:45 PM

LUM: 620

Measured at Mid-Point of Tuneable White CCT Range



Spectra

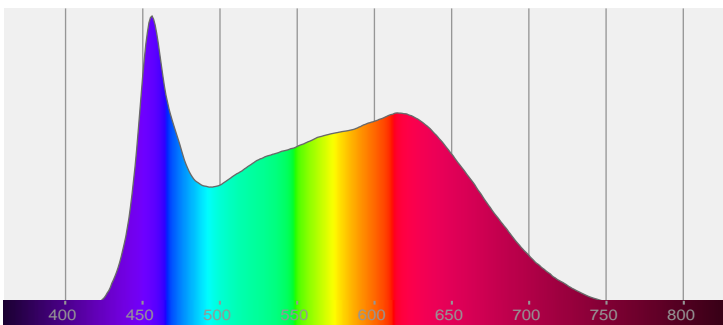

CRI: 93.6 (R1-R8)

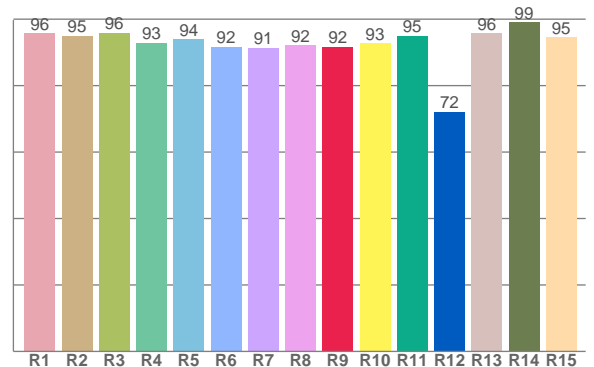

Color parameters

Color rendering index	Red component	Color fidelity	Color gamut	Color quality scale	Color coordinate cie 1931	Color coordinate cie 1931	Color coordinate	Color coordinate	Color deviation from black body
CRI	CRI R9	TM30 R _f	TM30 R _g	CQS	x	y	u	v	Δuv
93.6	91.6	90.0	98.7	92.0	0.356	0.345	0.221	0.322	-0.0073

R_f 90.0
Fidelity index R_f

R_g 98.7
Gammut index R_g

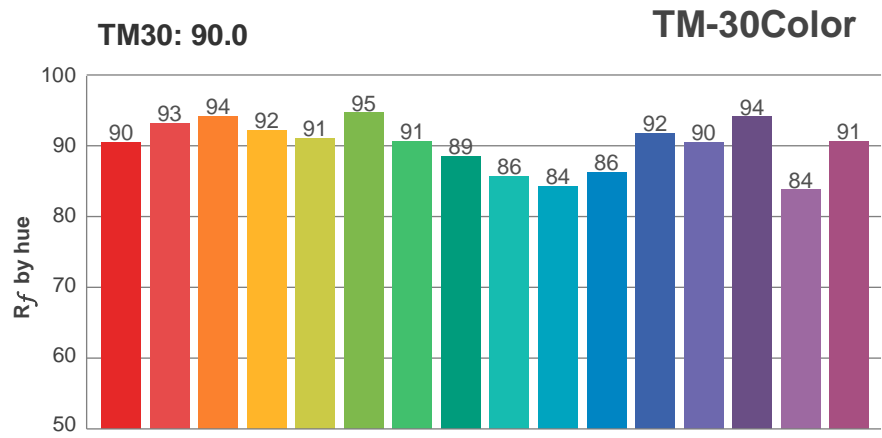

Hue Bin	R_f	Graphic shifts (%)	
		Chroma	Hue
1	90	-3%	3%
2	93	0%	2%
3	94	0%	2%
4	92	-2%	-2%
5	91	-6%	-2%
6	95	-3%	0%
7	91	-5%	3%
8	89	-2%	7%
9	86	-1%	11%
10	84	2%	10%
11	86	6%	7%
12	92	4%	-1%
13	90	3%	-6%
14	94	-1%	-2%
15	84	4%	-10%
16	91	-2%	-2%

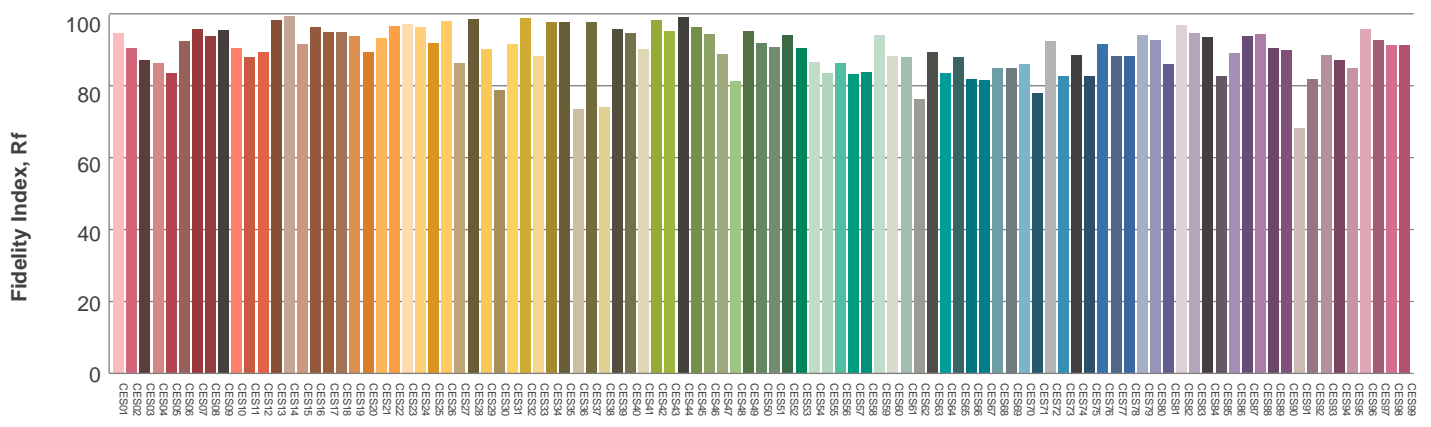
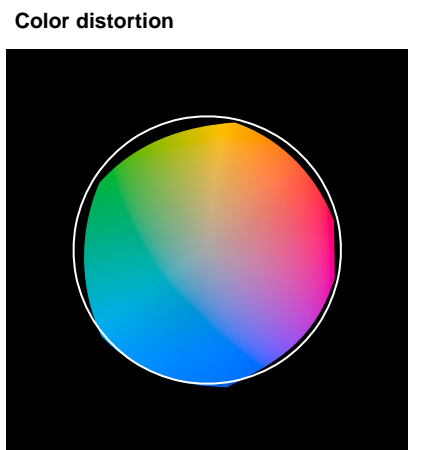
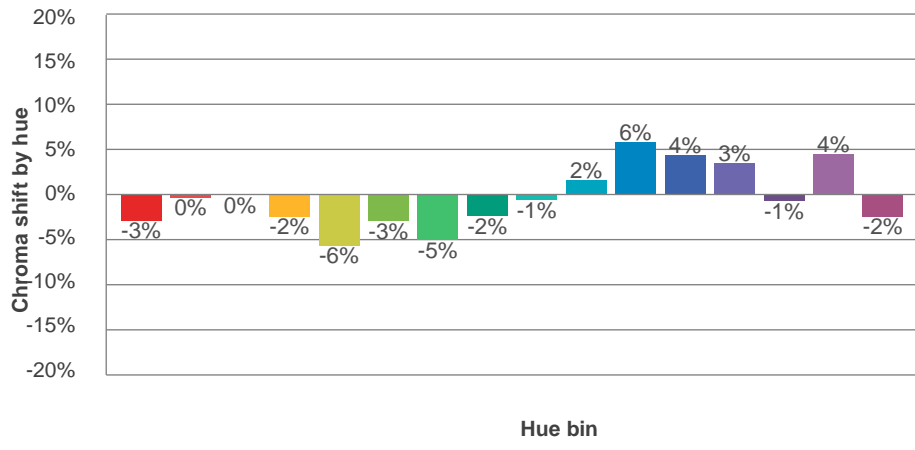
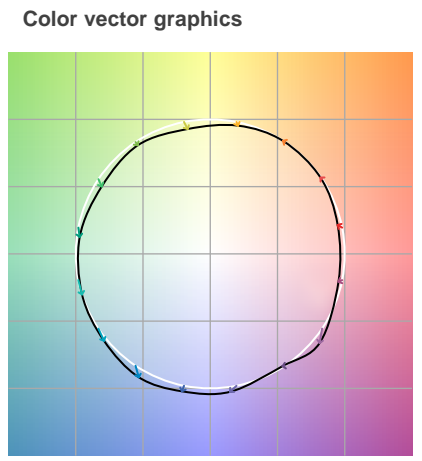
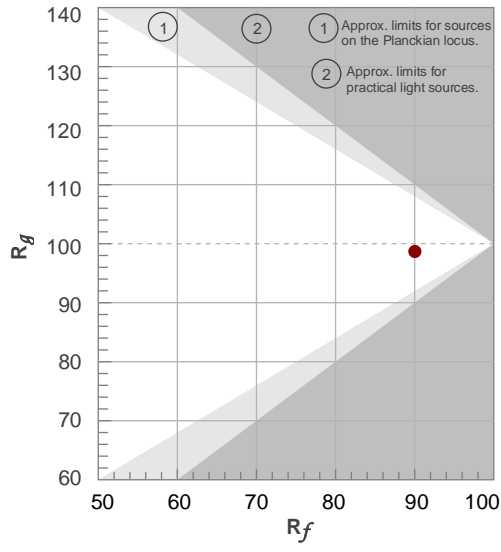

Beam details

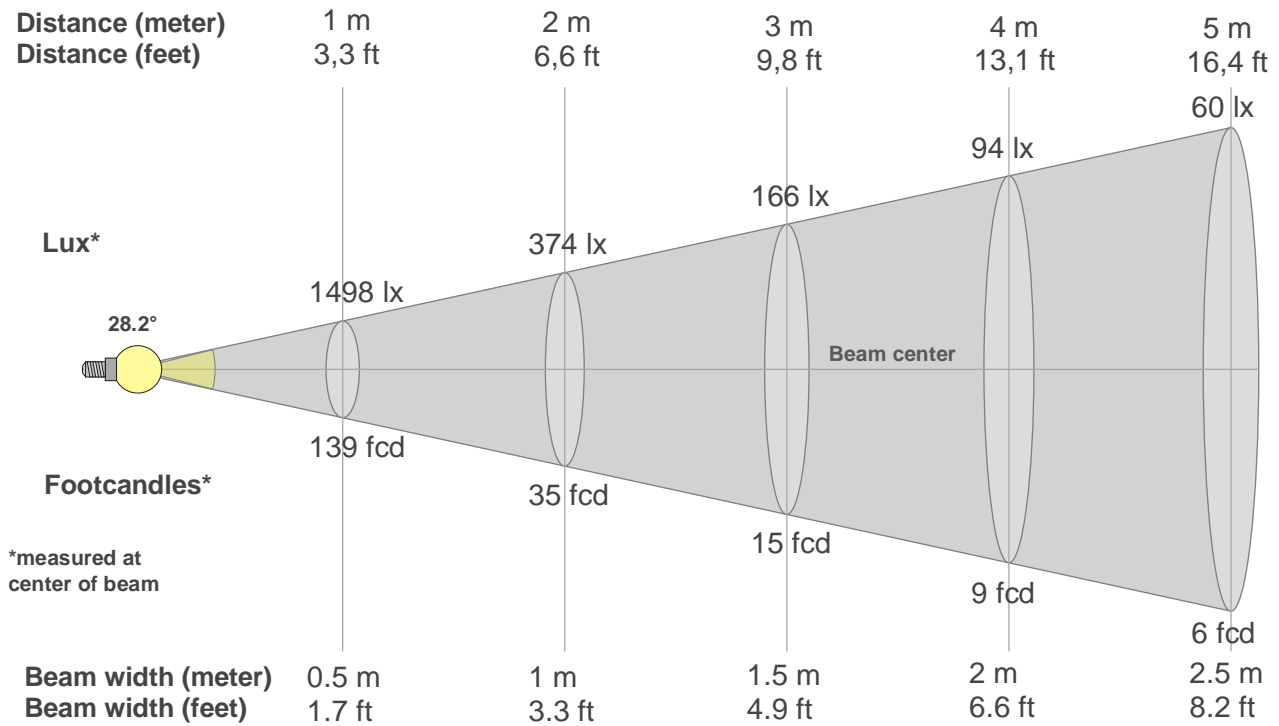

Beam intensities from 1-20m

1m	2m	3m	4m	5m	6m	7m	8m	9m	10m	11m	12m	13m	14m	15m	16m	17m	18m	19m	20m
3.3ft	6.6ft	9.8ft	13.1ft	16.4ft	19.7ft	23ft	26.2ft	29.5ft	32.8ft	36.1ft	39.4ft	42.7ft	45.9ft	49.2ft	52.5ft	55.8ft	59.1ft	62.3ft	65.6ft
1498lx	374lx	166lx	94lx	60lx	42lx	31lx	23lx	18lx	15lx	12lx	10lx	9lx	8lx	7lx	6lx	5lx	5lx	4lx	4lx
139.1fcd	34.8fcd	15.5fcd	8.7fcd	5.6fcd	3.9fcd	2.8fcd	2.2fcd	1.7fcd	1.4fcd	1.1fcd	1fcd	0.8fcd	0.7fcd	0.6fcd	0.5fcd	0.5fcd	0.4fcd	0.4fcd	0.3fcd

Intensities in 0° c-plane

0°	2°	4°	6°	8°	10°	12°	14°	16°	18°	20°	22°	24°	26°	28°	30°	32°	34°	36°	38°
1498	1491	1442	1372	1263	1120	953	760	601	487	411	363	325	297	287	276	247	188	139	103
100%	100%	96%	92%	84%	75%	64%	51%	40%	33%	27%	24%	22%	20%	19%	18%	16%	13%	9%	7%

Intensities in 90° c-plane

0°	2°	4°	6°	8°	10°	12°	14°	16°	18°	20°	22°	24°	26°	28°	30°	32°	34°	36°	38°
1498	1491	1442	1372	1263	1120	953	760	601	487	411	363	325	297	287	276	247	188	139	103
100%	100%	96%	92%	84%	75%	64%	51%	40%	33%	27%	24%	22%	20%	19%	18%	16%	13%	9%	7%

Intensities in 180° c-plane

0°	2°	4°	6°	8°	10°	12°	14°	16°	18°	20°	22°	24°	26°	28°	30°	32°	34°	36°	38°
1498	1491	1442	1372	1263	1120	953	760	601	487	411	363	325	297	287	276	247	188	139	103
100%	100%	96%	92%	84%	75%	64%	51%	40%	33%	27%	24%	22%	20%	19%	18%	16%	13%	9%	7%

Intensities in 270° c-plane

0°	2°	4°	6°	8°	10°	12°	14°	16°	18°	20°	22°	24°	26°	28°	30°	32°	34°	36°	38°
1498	1491	1442	1372	1263	1120	953	760	601	487	411	363	325	297	287	276	247	188	139	103
100%	100%	96%	92%	84%	75%	64%	51%	40%	33%	27%	24%	22%	20%	19%	18%	16%	13%	9%	7%

Beam angle 50%	Field angle 10%	Cutoff angle 2,5%	Intensity ratio in 120° cone	Intensity ratio in 90° cone
28.2°	71.1°	94.8°	97.8%	94.0%

LAMPS (number of lamps)

50

Light planning Luminaire budgetary diagram

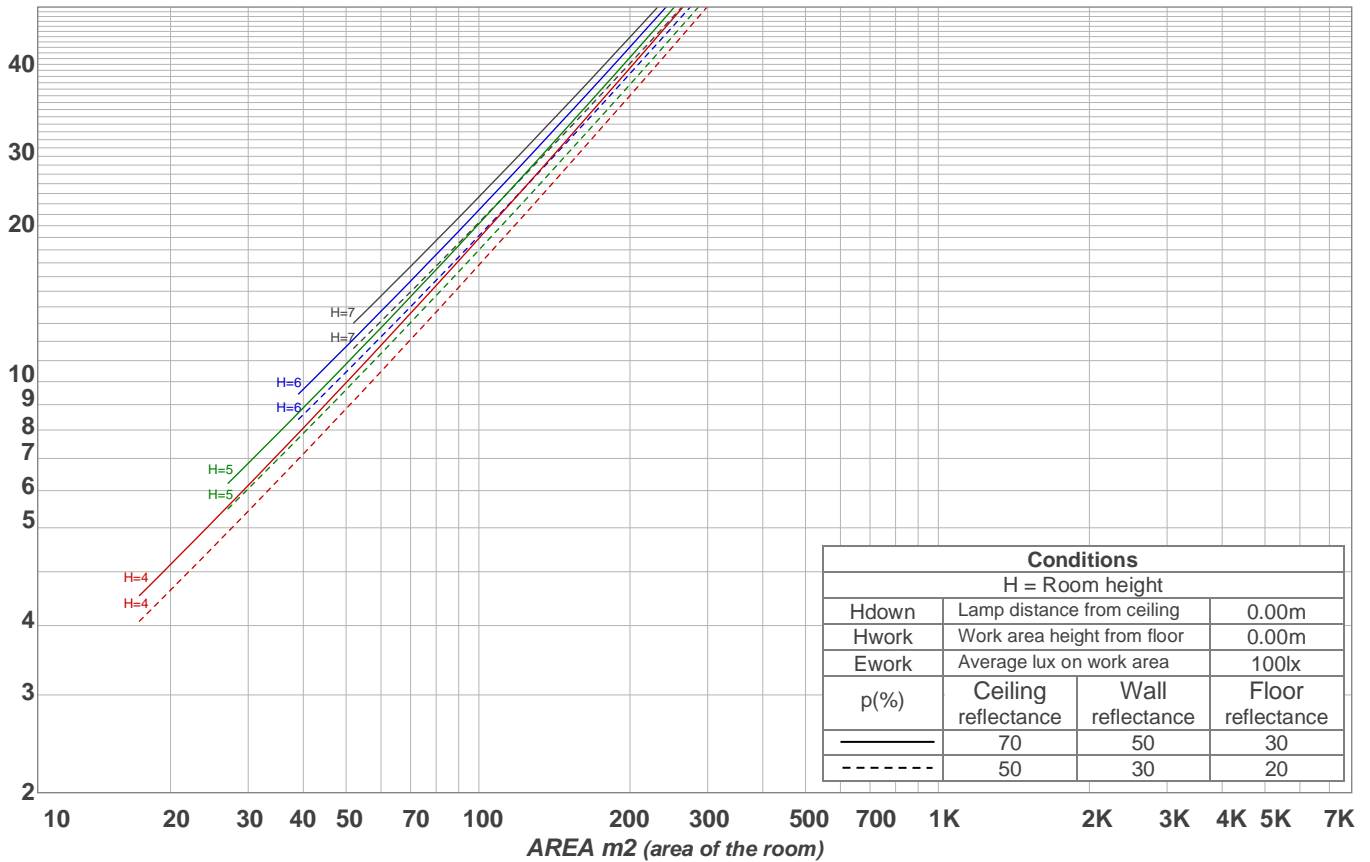

Luminaire budgetary diagram AREA m2 (area of the room) Coefficients of Utilization

Ceiling reflectance	80				70				50			30			10			0
Wall reflectance	70	50	30	10	70	50	30	10	50	30	10	50	30	10	50	30	10	0
Floor reflectance	20	20	20	20	20	20	20	20	20	20	20	20	20	20	20	20	20	0
RCR	(RCR: Room Cavity Ratio)																	
	Room Values are expressed as percentage of Lumens delivered to the task surface																	
0	119	119	119	119	116	116	116	116	111	111	111	106	106	106	102	102	102	100
1	114	111	109	107	111	109	107	105	105	103	102	101	100	99	98	97	96	94
2	109	104	100	97	106	102	99	96	99	96	94	96	94	92	93	91	90	88
3	104	98	93	89	102	96	92	88	94	90	87	91	88	86	89	86	84	83
4	99	92	87	83	97	91	86	82	89	85	81	87	83	80	85	82	79	78
5	94	87	81	77	93	86	81	77	84	80	76	82	79	76	81	78	75	74
6	90	82	77	73	89	81	76	72	80	75	72	79	75	71	77	74	71	70
7	87	78	72	69	85	77	72	68	76	71	68	75	71	68	74	70	67	66
8	83	74	69	65	82	74	68	65	73	68	65	72	67	64	71	67	64	63
9	80	71	65	62	79	70	65	62	69	65	61	69	64	61	68	64	61	60
10	77	68	62	59	76	67	62	59	67	62	59	66	61	58	65	61	58	57

Zonal Lumen Summary

0°-10°	10°-20°	20°-30°	30°-40°	40°-50°	50°-60°	60°-70°	70°-80°	80°-90°
126 lm	189 lm	147 lm	104 lm	36.0 lm	9.05 lm	4.17 lm	2.25 lm	1.90 lm
90°-100°	100°-110°	110°-120°	120°-130°	130°-140°	140°-150°	150°-160°	160°-170°	170°-180°
0.000 lm	0.000 lm	0.000 lm	0.000 lm	0.000 lm	0.000 lm	0.000 lm	0.000 lm	0.000 lm

UGR

p Ceiling	70	70	50	50	30	70	70	50	50	30	
p Walls	50	30	50	30	30	50	30	50	30	30	
p Floor	20	20	20	20	20	20	20	20	20	20	
Room size X Y	Viewing direction at right angles to lamp axis					Viewing direction parallel to lamp axis					
2H	2H	29.0	29.6	29.1	29.8	30.0	29.0	29.6	29.1	29.8	30.0
	3H	28.8	29.5	29.2	29.8	29.9	28.8	29.5	29.2	29.8	29.9
	4H	28.8	29.5	29.2	29.7	29.9	28.8	29.5	29.2	29.7	29.9
	6H	28.8	29.4	29.1	29.7	30.1	28.8	29.4	29.1	29.7	30.1
	8H	28.8	29.4	29.2	29.7	30.1	28.8	29.4	29.2	29.7	30.1
	12H	28.9	29.4	29.2	29.8	30.2	28.9	29.4	29.2	29.8	30.2
4H	2H	28.7	29.4	29.1	29.6	29.9	28.7	29.4	29.1	29.6	29.9
	3H	28.7	29.3	29.1	29.6	30.0	28.7	29.3	29.1	29.6	30.0
	4H	28.6	29.1	29.1	29.6	30.1	28.6	29.1	29.1	29.6	30.1
	6H	28.7	29.2	29.2	29.5	29.9	28.7	29.2	29.2	29.5	29.9
	8H	28.7	29.2	29.2	29.5	29.9	28.7	29.2	29.2	29.5	29.9
	12H	28.8	29.2	29.3	29.6	30.0	28.8	29.2	29.3	29.6	30.0
8H	4H	28.5	29.0	29.1	29.4	29.7	28.5	29.0	29.1	29.4	29.7
	6H	28.6	29.0	29.2	29.4	30.0	28.6	29.0	29.2	29.4	30.0
	8H	28.8	29.0	29.3	29.6	30.2	28.8	29.0	29.3	29.6	30.2
	12H	29.0	29.2	29.6	29.7	30.3	29.0	29.2	29.6	29.7	30.3
12H	4H	28.5	28.9	29.0	29.3	29.8	28.5	28.9	29.0	29.3	29.8
	6H	28.7	28.9	29.2	29.5	30.1	28.7	28.9	29.2	29.5	30.1
	8H	28.8	29.0	29.4	29.5	30.1	28.8	29.0	29.4	29.5	30.1

Corrected glare indices referring to 620 lm total luminous flux